



GUIDANCE NOTES ON

**SAFEHULL FINITE ELEMENT ANALYSIS OF HULL
STRUCTURES**

DECEMBER 2004

**American Bureau of Shipping
Incorporated by Act of Legislature of
the State of New York 1862**

**Copyright © 2004
American Bureau of Shipping
ABS Plaza
16855 Northchase Drive
Houston, TX 77060 USA**

This Page Intentionally Left Blank



GUIDANCE NOTES ON SAFEHULL FINITE ELEMENT ANALYSIS OF HULL STRUCTURES

CONTENTS

SECTION 1	Introduction	1
1	Objectives	1
3	Scope of Application	1
5	Overview of Analysis Procedure	1
7	Required Analyses	2
9	Supplementary Analyses	3
	 FIGURE 1 Overview of the FEA Model Functions and Analyses for SafeHull TSA	 2
SECTION 2	Global 3D FEA Model	5
1	General	5
3	Extent of the Global 3D FEA Model	5
5	Coordinate and Unit System of the Global Model	9
7	Element Types and Combination	10
9	Finite Element Modeling	11
	9.1 Model for Responses	11
	9.3 Element Size	11
11	FEA Model Verification	17
13	SafeHull Verification Tools	18
	 TABLE 1 Recommended Baseline Mesh Size and Mesh Order for Global Model	 12
	 FIGURE 1 Extent of the 3D Global Model and Mesh Arrangement for Tankers	 6
	 FIGURE 2 Extent of the 3D Global Model and Mesh Arrangement for Bulk Carriers	 7
	 FIGURE 3 Extent of the 3D Global Model and Mesh Arrangement for Container Carriers	 8
	 FIGURE 4 Model Coordinate System	 9
	 FIGURE 5 Typical Mesh Arrangement of Aframax Oil Tankers	 13

FIGURE 6	Typical Mesh Arrangement of VLCC Oil Tankers.....	14
FIGURE 7	Typical Mesh Arrangement of Cape Size Bulk Carriers	15
FIGURE 8	Typical Mesh Arrangement of Container Carriers	16
FIGURE 9	SafeHull Nastran Model Check Tool.....	18
FIGURE 10	SafeHull Groups and Displays the Model by Grouping Parts.....	18

SECTION 3 Loading and Boundary Conditions 19

1	General	19
3	Loading and Loading Patterns.....	19
5	Load Combination Factor and Load Cases	20
7	Identify Compartments.....	20
9	Apply Load Components to Compartment Boundaries	21
11	Pressure Superposition and Force Conversion.....	21
13	Hull Girder Loads and Load Equilibrium	22
15	Boundary Conditions.....	23
15.1	Supporting Rod and Its Property	23
15.3	Tankers	24
15.5	Bulk Carriers.....	26
15.7	Containership Models.....	27
15.9	Boundary Constraint Beams on the Two End Sections...28	

TABLE 1	Steel Vessel Rules Specified Loading Criteria (150 m or More in Length)	19
---------	---	----

TABLE 2	Steel Vessel Rules Specified Loading Patterns.....	20
---------	--	----

TABLE 3	Steel Vessel Rules Specified Loading Combination Factors	20
---------	--	----

FIGURE 1	SafeHull “View Tank Boundaries” and “Search Log File” Tools	21
----------	---	----

FIGURE 2	SafeHull “View Tank and Frame Load” Tool.....	22
----------	---	----

FIGURE 3	View Curves of Hull Girder Load in the SafeHull System	23
----------	--	----

FIGURE 4	Spring Supports for Tanker Global Models.....	25
----------	---	----

FIGURE 5	Spring Supports at Fore End of Bulk Carrier Global Models.....	26
----------	--	----

FIGURE 6	Spring Supports at Aft End for Container Carrier Global Models	28
----------	--	----

FIGURE 7	Spring Supports at Fore End for Container Carrier Global Models	28
----------	---	----

SECTION 4 Evaluation..... 31

1	General	31
---	---------------	----

3	Checking Global Model Response	31
---	--------------------------------------	----

5	Plate Panels for Evaluation.....	33
---	----------------------------------	----

7	Yielding Strength.....	33
7.1	Yielding Criteria for Watertight Members	33
7.3	Yielding Criteria for Non-watertight Members	34
9	Buckling Strength.....	34
9.1	Buckling Criteria for Watertight Members.....	34
9.3	Buckling Criteria for Non-Watertight Members	34
11	Fatigue Strength	35
TABLE 1	Steel Vessel Rules-specified Loading Criteria (150 meters or more in length).....	31
FIGURE 1	View FEA Solution in SafeHull System.....	32
FIGURE 2	Overall Deformation of Three Cargo Model for Load Case 1	32
SECTION 5	Critical Areas	37
1	Tanker.....	37
1.1	Transverse Web.....	37
1.3	Horizontal Stringer Sections.....	39
1.5	Longitudinal Girder Sections	39
3	Bulk Carrier	39
5	Containership.....	43
FIGURE 1	Critical Areas – Tankers.....	37
FIGURE 2	Critical Areas for Typical General Bulk Carriers	41
FIGURE 3	Critical Areas for Typical Containerships, Transverse Sections	44
FIGURE 4	Critical Areas for Typical Containerships, Deck & Longitudinal Section.....	45
SECTION 6	Frequently Asked Questions	47
SECTION 7	References.....	51

This Page Intentionally Left Blank



SECTION 1 Introduction

1 Objectives

This document provides the guidelines of the Finite Element Analysis (FEA) approach for ABS SafeHull Total Strength Assessment (TSA) of hull structures, as specified in the *ABS Rules for Building and Classing Steel Vessels*, which are referred to herein as the “*Steel Vessel Rules*”. The analysis approach considered in this Guide uses a 3D global FEA model with sufficient mesh density to assess both global hull-girder and local main supporting structural yielding and buckling strengths. A local very fine mesh model may be required when a detail design or critical structural area needs to be analyzed. This approach is referred to as “Global 3D Fine Mesh FEA Method”. It differs from an earlier method that used separate steps for global coarse mesh and local fine mesh analyses. Structural idealization, load application, analysis procedures and evaluation of analysis results are carried out in a consistent manner based on sound engineering practice. This Guide also provides the necessary information to help the users with the ABS SafeHull TSA system.

3 Scope of Application

This Guide is provided for the finite element structural analysis of tankers*, bulk carriers and container carriers, as specified in the *Steel Vessel Rules*. The instructions given regarding load application and strength evaluation are the loading (both the load cases and loading patterns) and strength criteria specified in the *Steel Vessel Rules* for assessing these ship types.

The strength criteria in Part 5 of the *Steel Vessel Rules* are based on a “net” ship approach. Therefore, the corrosion margins specified in the *Steel Vessel Rules* are to be deducted from the design scantlings for the finite element modeling and strength assessment of the hull structures.

This Guide presents information relating to the “Global 3D Fine Mesh FEA” method, as required to receive the ABS SafeHull Notation. Information related to the critical areas, local finer mesh and very fine mesh modeling and analyses are also discussed here. The users should follow the Rules-required and supplementary analyses, as shown in Section 1, Figure 1, as well as the model special requirements to determine the FEA modeling and analysis.

* *Note:* Similarly, the finite element structural analysis as specified in this Guide may be used for the analysis of membrane tank SH LNG carriers. The information on the LNG carriers, typical modeling and example of analysis will be provided by the ABS Engineering Office, if necessary, until the next edition of the Guide is published.

5 Overview of Analysis Procedure

The SafeHull FEA analysis is used to determine the structural responses of the vessels to the load cases specified in the *Steel Vessel Rules*. This requires developing a series of FEA models of the ship structures and applying the *Steel Vessel Rules*-specified loading conditions to determine the deflections and stresses of the structures. The solved FEA results are evaluated against the *Steel Vessel Rules* acceptance strength criteria. ABS has developed the SafeHull system to help the users perform the mentioned loading and evaluation analyses for global, local fine mesh and fatigue fine mesh models.

FEA is an open-ended, general-purpose tool that is used to varying degrees and levels of details ranging from the general global structural responses to very fine detail stress concentrations. The analysis scope and level of details must be matched to the acceptance criteria. The Rules include acceptance criteria associated with certain levels of the analysis performed on different FE models. An overview of the Rules-required and supplementary analyses, as well as the functions of the different levels of the FEA models and corresponding evaluations are shown in Section 1, Figure 1. However, it is understood that users may want to perform additional supplementary analyses for better understanding of the vessel's structural behavior and strength.

FIGURE 1
Overview of the FEA Model Functions and Analyses for SafeHull TSA

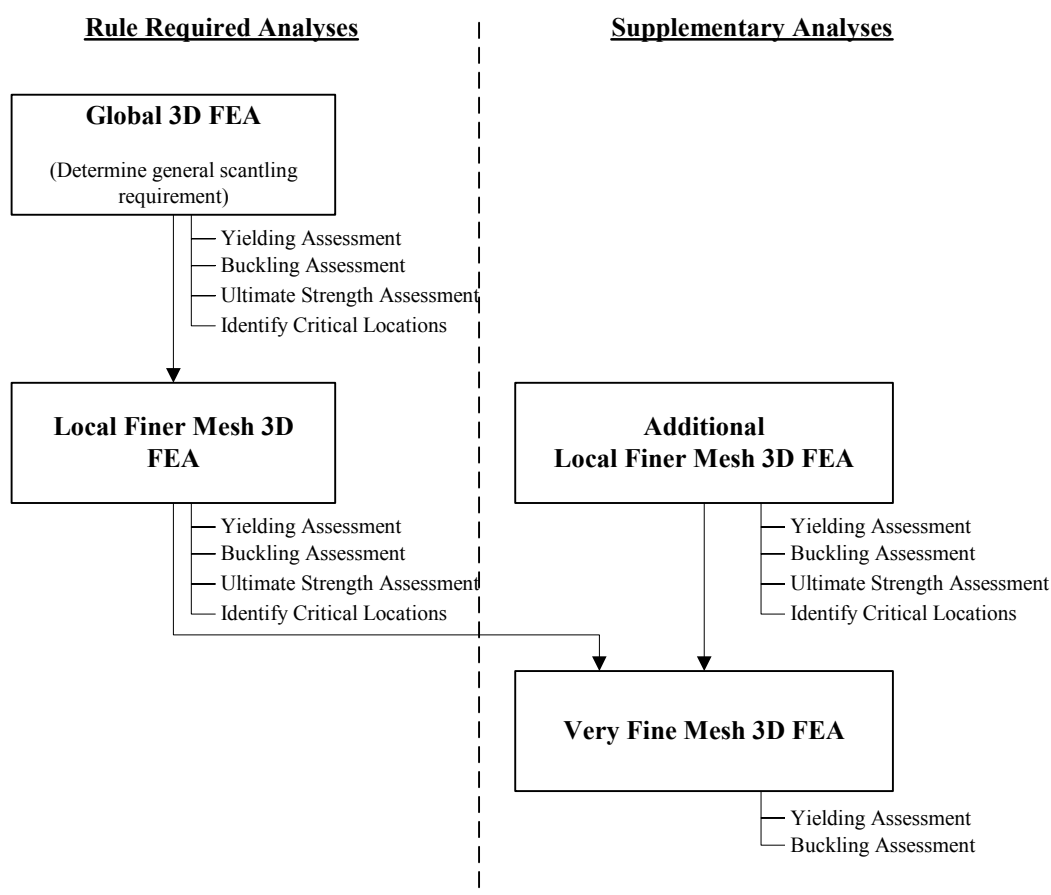

7 Required Analyses

As shown in Section 1, Figure 1, SafeHull total strength assessment requires the global and local finite element analyses in association with the *Steel Vessel Rules*-specified loading and evaluation criteria to ensure the ship structures meet the yielding, buckling and ultimate strength requirements. The global model analysis mainly focuses on the general scantling requirements for the structural members, such as longitudinal members (watertight), transverse bulkheads (watertight or non-tight) and main supporting members (non-tight), while the local finer mesh model analysis mainly focuses on the special requirements for the “critical areas”, such as the connections, openings, bracket toes, structural knuckle points, corners of large openings and so on.

9 Supplementary Analyses

Users may perform additional finer mesh analyses to verify that the structures are adequately designed. As no two structures are exactly alike, load generation techniques and analysis objectives differ. A certain amount of engineering judgment must be used to decide the level and detail to which the analysis should be carried out.

Issues that may dictate the need for additional analysis are listed, but not limited to, as follows:

- Known problem areas of similar structural arrangements or details
- The areas where relatively high stress levels were found in Global 3D FEA
- Suspected areas or details not adequately represented in the global models

Areas that might be subjected to finer mesh analyses are listed, but not limited to, as follows:

- Access openings in horizontal girders
- Bracket toes of main supporting structures
- Hopper corner details
- Hatch corners

Section 5, “Critical Areas”, of this Guide includes a discussion of typical critical areas that might be subjected to additional finer mesh analyses.

This Page Intentionally Left Blank



SECTION 2 Global 3D FEA Model

1 General

The global 3D FEA model is a representative of the hull structures of three cargo holds (or tanks, in the case of an oil carrier) with the middle cargo hold within $0.4L$ amidships. It is used to determine both the global response of the hull girder and local behavior of the main supporting structures. The stress results from such models must be suitable for strength evaluation of the watertight boundaries of cargo holds (or tanks) and non-tight main supporting structures. The global 3D FE analyses establish the scantling requirements of plates and stiffeners, and they are sufficient for establishing the steel weight estimate. Structural details are evaluated by the subsequent local 3D FE analyses.

The strength assessment procedures in this Guide are based on a “net” ship approach, wherein the nominal design corrosion values are to be deducted. The “net” thickness or scantlings correspond to the minimum strength requirements acceptable for classification, regardless of the design service life of the vessel. In addition to the coating protection specified in the *Steel Vessel Rules* for all ballast tanks, the minimum corrosion values for plating and structural members, as given in the *Steel Vessel Rules* (Section 5-1-3 for oil carriers, Section 5-3-3 for bulk carriers, Section 5-5-3 for container carriers) are to be applied. These minimum values are used solely for the above purpose and are not to be construed as renewal standard.

In view of higher corrosion rates for structural members in some regions, such as high-stressed areas, additional design margins are considered for the primary and critical structural members to minimize repairs and maintenance costs. The beneficial effects of these design margins on the reduction of stress and the increased effectiveness of the hull girder section modulus can be appropriately accounted for in the design evaluation. However, extra scantlings, such as owner-specified additional thickness, included in the vessel’s design specifications, should not be used in the finite element models.

3 Extent of the Global 3D FEA Model

To evaluate the vessel’s structures within $0.4L$ amidships with reasonable accuracy, the finite element models ideally place the target cargo hold in the middle and extend approximately the length of the adjacent holds fore and aft. In addition, there is a short extension beyond the transverse bulkheads at both ends.

Section 2, Figures 1, 2 and 3 show the extent of the typical finite element models for oil carriers, bulk carriers and container carriers, respectively.

Even though the ABS SafeHull system can handle both full and half-width models, it is recommended that the finite element models should be created with both the port and starboard sides of cargo hold structures, that are symmetrical with respect to the centerline, for easier review, result analysis and subsequent strength evaluation.

Within $0.4L$ amidships of some container carriers, the length of the parallel mid-body is usually less than one cargo hold length. During the initial design stage, only the midship section drawing is available. In this case, it is assumed that all three cargo holds have the same prismatic shape in order to determine the scantlings of the typical transverse sections and double bottom structures. However, the lower part of the hull structures should be evaluated using the actual hull shape. Accordingly, it is advisable to start with a simple prismatic model followed by an actual shape model.

FIGURE 1
Extent of the 3-D Global Model and Mesh Arrangement
for Tankers

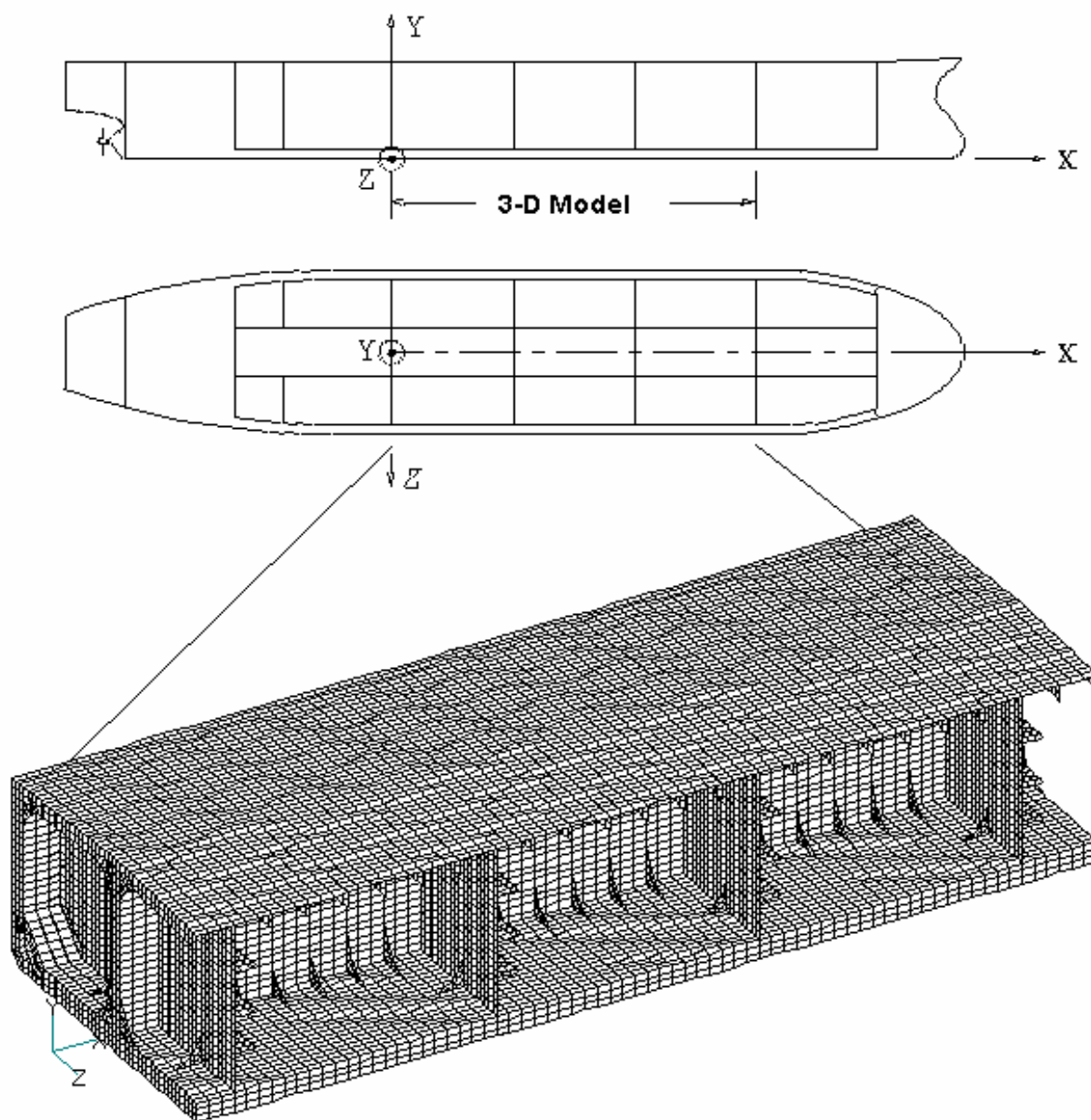

FIGURE 2
Extent of the 3D Global Model and Mesh Arrangement
for Bulk Carriers

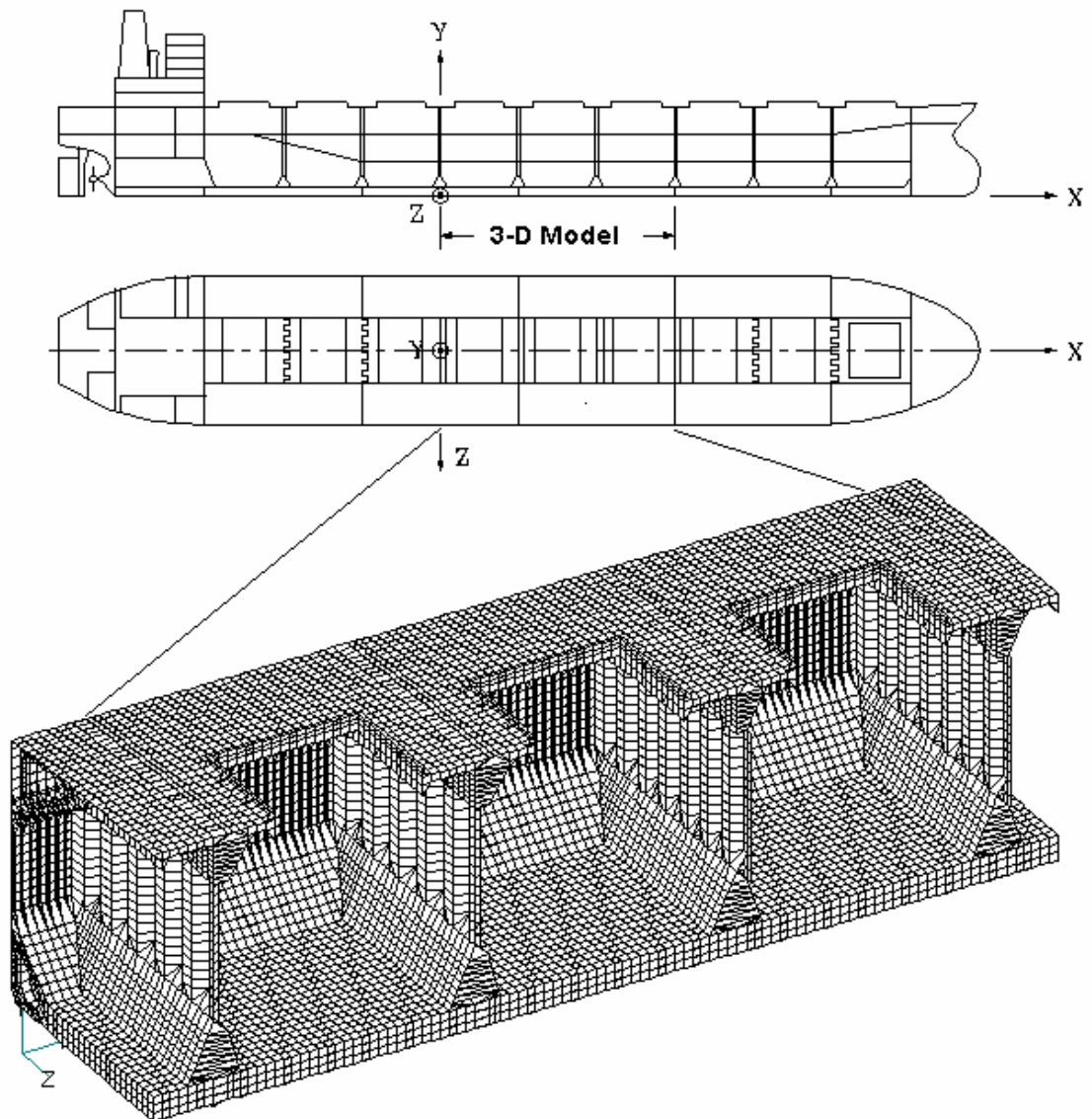
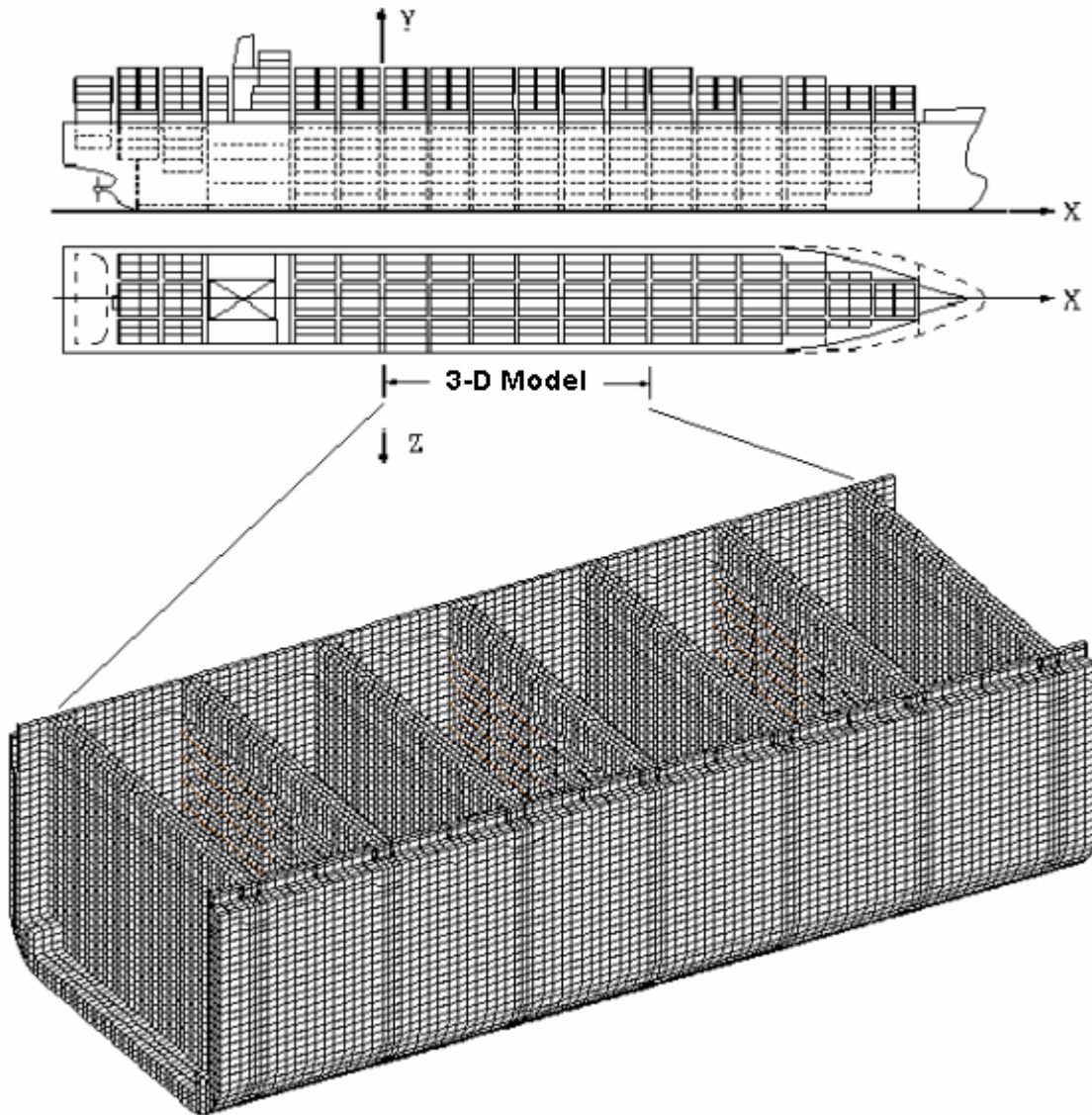

FIGURE 3
Extent of the 3D Global Model and Mesh Arrangement
for Container Carriers



5 Coordinate and Unit System of the Global Model

In this Guide, as well as within the SafeHull software system, the global coordinate (right-hand) system of this reference finite element model is defined as follows and shown in Section 2, Figure 4:

- X-axis: Longitudinal, positive from aft to fore
- Y-axis: Vertical, positive upward
- Z-axis: Transverse (athwart-ship), positive toward starboard

X-origin can be at any model longitudinal location, but it is recommended that X-origin be located at the aftermost bulkhead of three cargo holds. The Y-origin and Z-origin must be located at the intersection of the baseline and centerline planes.

The SafeHull software system is using engineering metric units and they are:

- Length: Centimeter (cm)
- Force: Kilogram force (kg force)
- Mass: Kilogram (kg)

Therefore, the stress is in kg/cm^2 .

Since the users may create FE models for other purposes, they may not match the above coordinate and unit system requirements. The SafeHull system provides a tool to convert the user's right-hand coordinate system into the SafeHull-required coordinates and units.

It should be mentioned that after the users decide the X-origin to be used for the global model, this origin is used for all of the sub-models. The SafeHull system provides a conversion tool to be used on all sub-models created outside of SafeHull.

FIGURE 4
Model Coordinate System

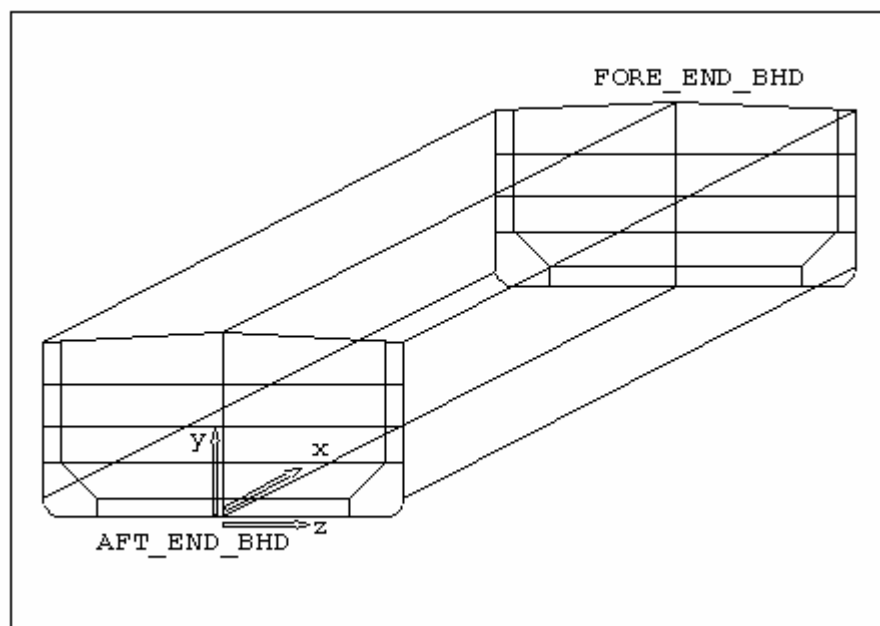

7 Element Types and Combination

In general, the ship structural FE model, whose geometry, configuration and stiffness approximate the actual ship hull structures, consists of four types of elements:

For stiffeners:

- Truss element (rod element) with axial stiffness only and a constant cross-sectional area along the length of the element.
- Beam element with axial, torsional and bi-directional shear and bending stiffness with constant properties along the length of the element.

For plates:

- Membrane plate element (i.e., plane-stress element) with bi-axial and in-plane shear stiffness and constant thickness.
- Bending plate element with in-plane stiffness as the membrane element plus out-of-plane bending stiffness and constant thickness.

These four simple types of elements are considered sufficient to represent the hull structures even though higher order element types exist.

Ship structures consist of various stiffened plates. These stiffened plates are represented by a combination of membrane plates and rod elements as long as only in-plane stress is calculated from the model. This is the case for the global 3D FE approach. Since rod elements lack out-of-plane load carrying capability, all loads applied on the intermediate nodal points of rod elements must be shifted to the adjacent primary supporting structures while associated singularity problems of unsupported nodal points are dealt with by slave-master constraints. These tasks are automatically handled in the SafeHull system.

The basic approach of shifting load technology is to find the nearest master node in the predetermined orientation, which has sufficient stiffness in the degree of freedom of which the slave node has zero or very small stiffness. If slave/master relationship is established, load acting on slave node is shifted to master node. The orientation determination is based on the structural member. In general, the search for the longitudinal members is in the longitudinal direction and the search for the transverse bulkheads is in the vertical direction. The radiation search is used for slave nodes of complicated structures, if their master nodes can't be found within the search range.

Combined use of membrane plates and rod elements may simplify the modeling processes and reduce the total number of degrees of freedom in the model. However, additional operations, such as shifting load, may result in less accurate results for some elements.

Combination of bending plates and beam elements is preferable, since computer technology has advanced to the point that computing time is not an issue for the FE analysis.

If beam elements are used to model the stiffeners, eccentric beams (with their neutral axis offset from the attached nodes) should not be used. SafeHull software separately estimates such an effect during strength evaluation. Appropriate properties of beam elements are assigned by considering equivalent concentric beams. This process is using the effective plate width (i.e., individual space of stiffeners) in the calculation of moment of inertia and assuming the neutral axis being located at the center layer of the attached plate. Attached plates are excluded from the calculation of sectional areas of beam elements.

Combined use of bending and membrane plate elements is not a common practice. However, this does not preclude the combined use of rod elements (faceplates) and bending plates (web plates) for main supporting structures.

9 Finite Element Modeling

9.1 Model for Responses

For the strength assessment of ship structures within 0.4L amidships, the finite element model is constructed to capture the following structural behaviors:

- *Primary bending stress and deformation.* This is a beam-like hull girder bending induced by hull girder loads (i.e., bending moment and shear force). The plating acts like a membrane and the resulting “primary stress” is wholly in-plane membrane stress.
- *Secondary bending stress and deformation.* The stiffened panels, such as side shell, longitudinal bulkhead and double bottom, deform under local loads between transverse bulkheads. The resulting “secondary stress” is also in plane, since hull girder plating acts as a flange of longitudinal girders.
- *Additional secondary bending.* The stiffened panels between transverse web frames deform under local loads. The resulting “additional secondary stress” is also in plane, since hull girder plating in this case acts as a flange of longitudinal stiffeners.
- *Tertiary bending.* The plating bends locally between stiffeners due to local pressure load. The resulting “tertiary stress” is out-of-plane bending stress of the plate, linearly distributed across the thickness, having compressive and tensile stresses on the two surfaces of the plate.

In addition, we may define the stresses in the transverse internal structures, as follows:

- *Reliable stress and deformation on transverse bulkheads.* This stress includes those induced by “large panel bending and deformation” (i.e., an entire bulkhead) and stiffened panels deformed between the horizontal girder supports.
- *Reliable stress and deformation of all main supporting members for yielding and buckling evaluations.* The major factor in this stress and deformation is the mesh density for the main supporting member.

9.3 Element Size

As discussed in Subsection 2/7, additional secondary bending stress due to small stiffeners is calculated separately from the FE results. Tertiary stress is also calculated separately. Therefore, mesh size of global FE models should not be so fine as to include the effects of tertiary stress in the FE results.

Accordingly, mesh sizes for global FE models should be one longitudinal frame space (about 800 ~ 900 mm) in longitudinal, transverse and vertical directions. The guidelines for a desirable meshing arrangement are listed below:

- Longitudinally, three or more elements between two adjacent web frames fore and aft of a transverse bulkhead (aspect ratio approximately equal to 1.0)
- Longitudinally, at least two elements between two adjacent web frames, away from transverse bulkheads (aspect ratio not to exceed 3.0)
- Three or more elements over the depth of the double bottom floors, girders, side transverse webs, side stringers, vertical webs and horizontal stringers on transverse bulkheads (aspect ratio approximately equal to 1.0)

In summary, the guidelines for the mesh size of each structural member are listed in Section 2, Table 1.

TABLE 1
Recommended Baseline Mesh Size and Mesh Order for Global Model

<i>Structural Members and Mesh order</i>	<i>Transverse or Vertical</i>	<i>Longitudinal</i>
<i>Watertight Members:</i>		
Side shell Inner skin bulkhead Bottom Inner bottom Deck Longitudinal bulkhead	$1 \times s$ The mesh size on these members controls the meshing in other members	$ws/2$ to $ws/4$ Prefer to have the finer mesh ($ws/4$) near the transverse bulkhead and a uniform mesh is desired
Corrugated bulkhead structure	Controlled by corrugation and above	Controlled by corrugation and above
Transverse bulkhead	Same as above	N/A
<i>Non Watertight Members:</i>		
The following is for the boundary mesh control. Internal mesh may vary to fit with internal structural configuration		
Side transverse web Bottom floor Deck transverse Cross deck structures Swash bulkhead	$1 \times s$ or controlled by watertight members above	N/A
Side stringer Bottom longitudinal girder Cross deck	Same as above	$ws/2$ to $ws/4$ or controlled by watertight members' meshing
Horizontal stringer	Same as above	Same as above

Notes:

- s = longitudinal stiffener spacing
 ws = web frame spacing

Although not recommended, some users may prefer including the structural details in the global FE models. In order for this purpose, finer mesh sizes may be required and appropriate mesh sizes depending on different structural details are explained in the separate document "Guidance Notes on Finite Element Analysis of Hull Structures – Local 3D Model Analysis".

Generally, standard mesh sizes must be applied throughout the models, and the structural details are evaluated separately, either by local fine mesh finite element models or justified by good in-service experience.

It is not recommended to model openings by deleting elements or reducing plate thickness. Resultant stresses from such modifications may result in unrealistic stress distribution. However, if openings are not modeled, resultant stresses should be appropriately adjusted before evaluation..

Section 2, Figures 1, 2 and 3 show the overall mesh arrangement of a global model for tankers, bulk carriers and container carriers, respectively.

Section 2, Figure 5 shows the mesh arrangement of the inside structures for an Aframax oil tanker.

Section 2, Figure 6 shows the mesh arrangement of the inside structures for a VLCC oil tanker.

Section 2, Figure 7 shows the mesh arrangement of the inside structures for a cape size bulk carrier.

Section 2, Figure 8 shows the mesh arrangement of the inside structures for a container carrier

FIGURE 5
Typical Mesh Arrangement of Aframax Oil Tankers

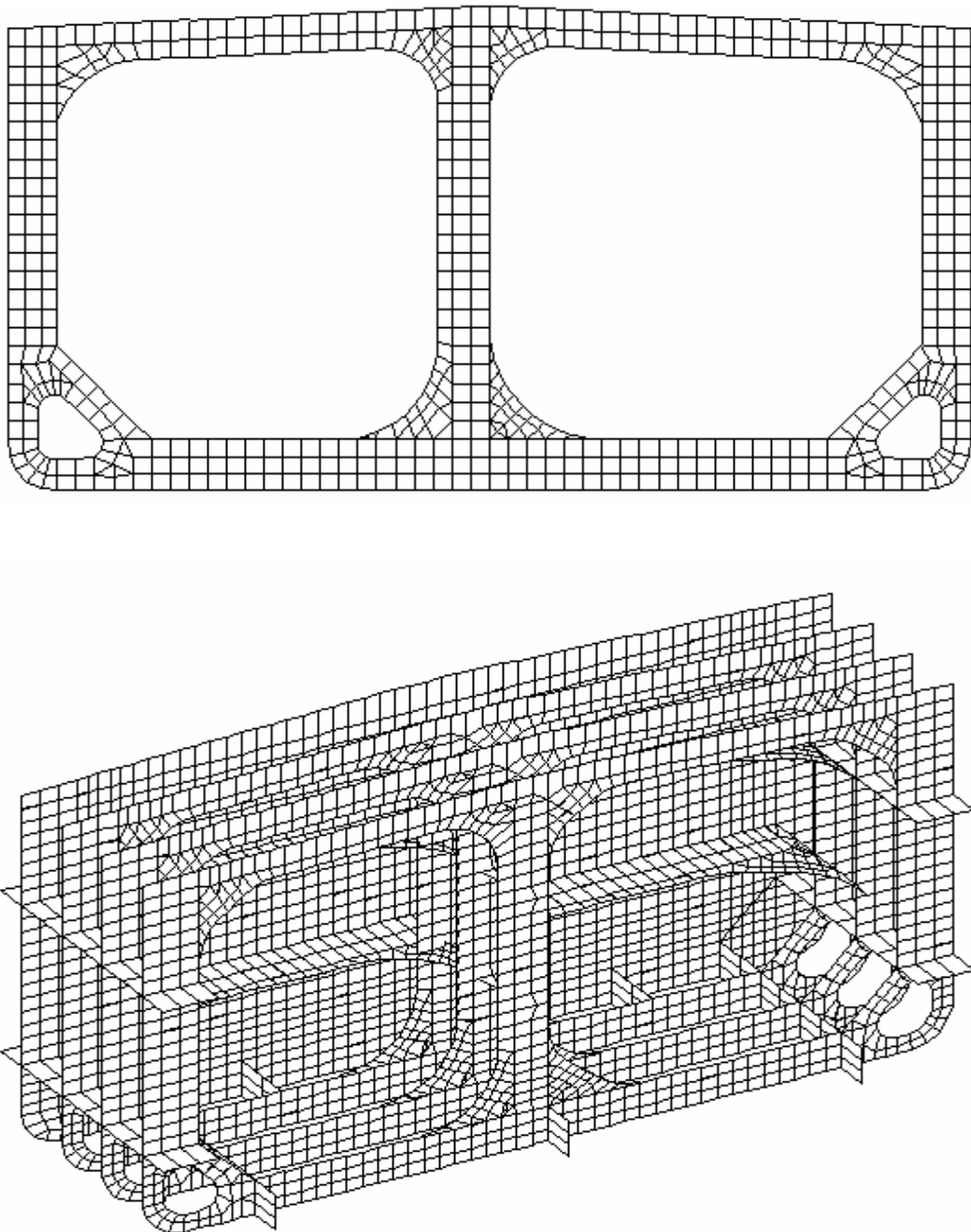

FIGURE 6
Typical Mesh Arrangement of VLCC Oil Tankers

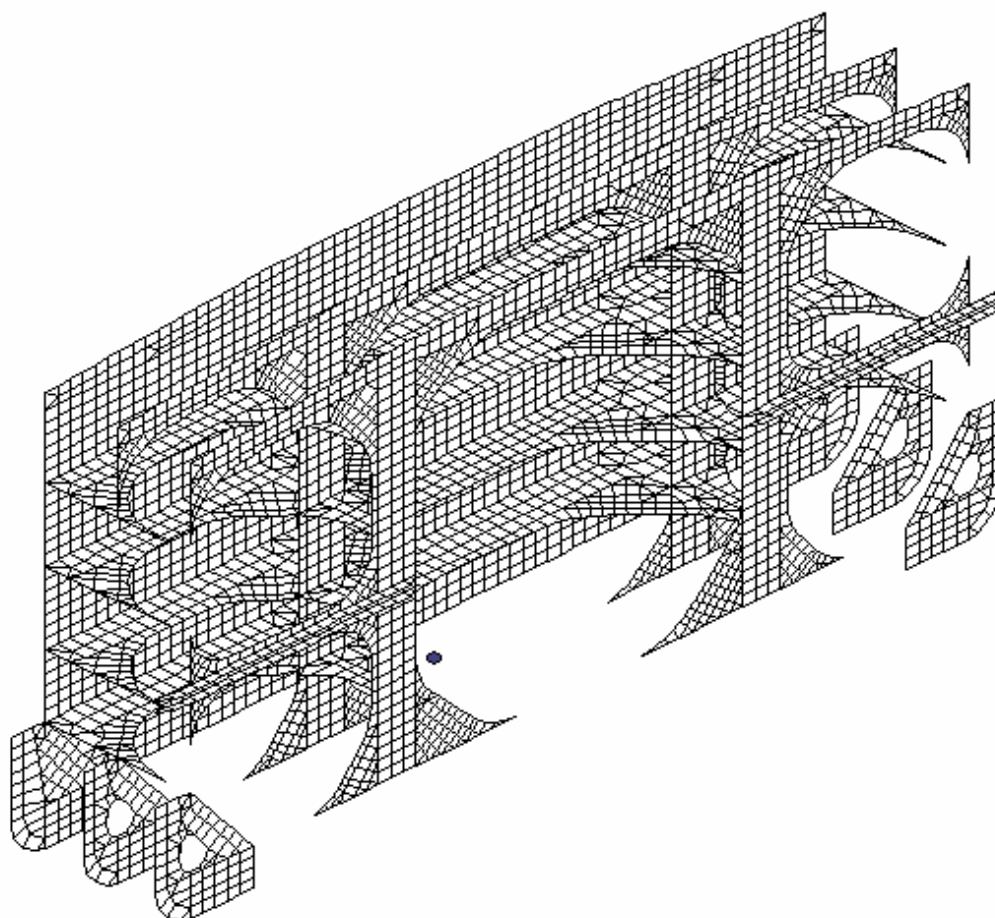
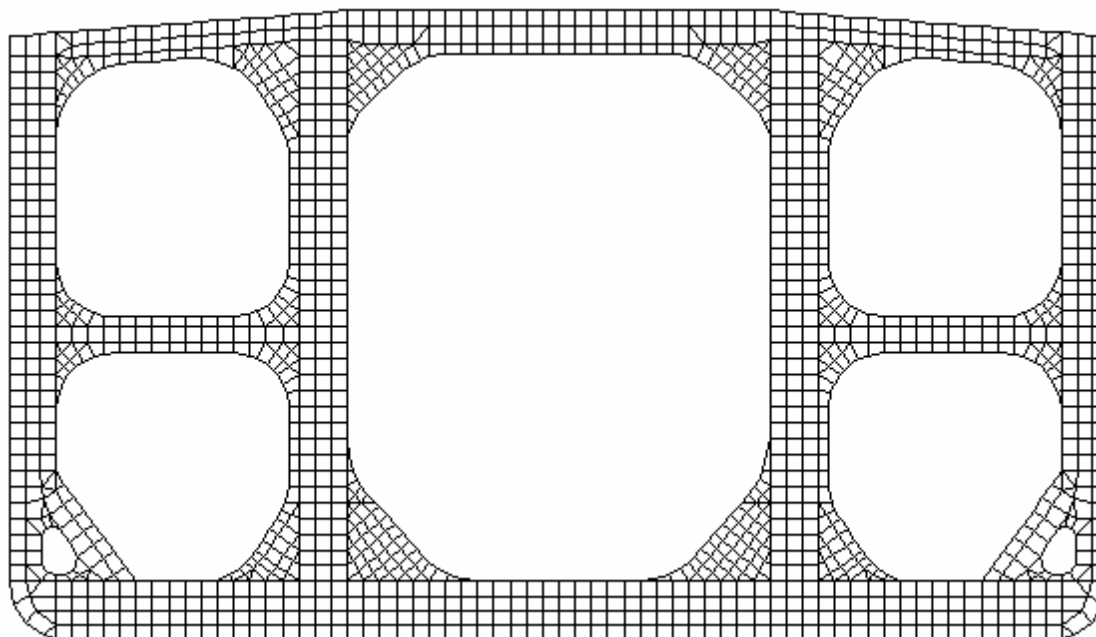

FIGURE 7
Typical Mesh Arrangement of Cape Size Bulk Carriers

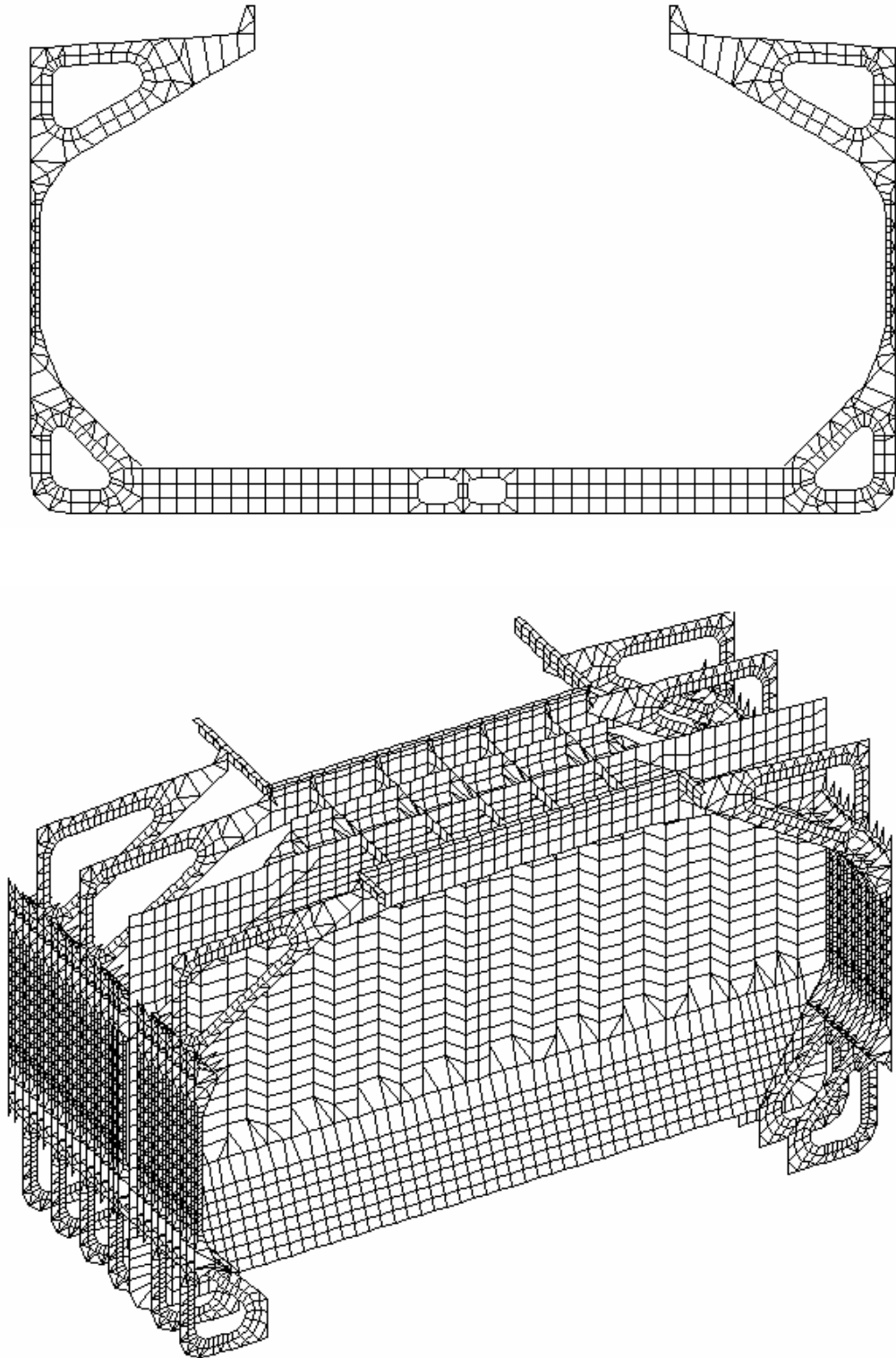
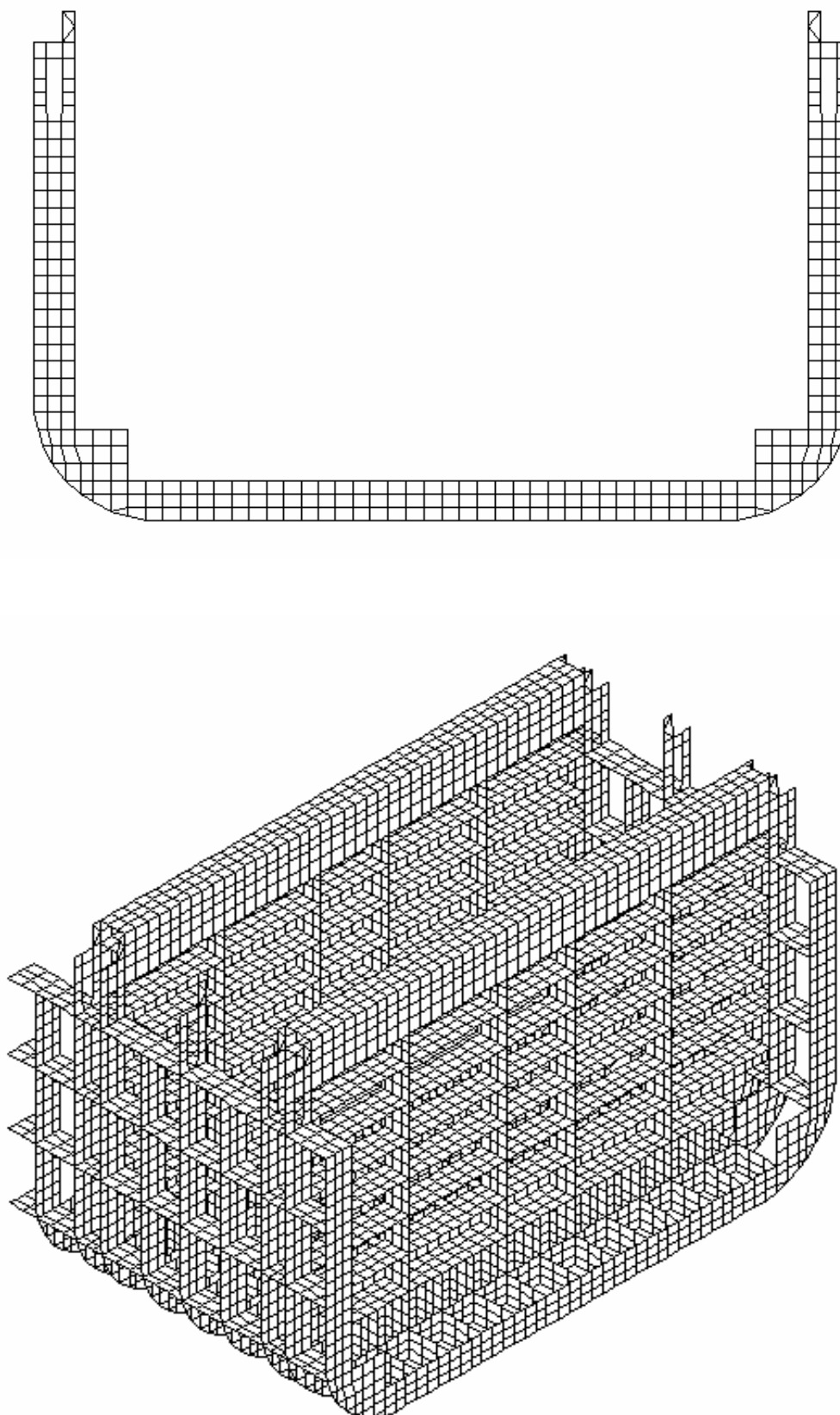

FIGURE 8
Typical Mesh Arrangement of Container Carriers



11 FEA Model Verification

To ensure the quality of the analysis results, an FE model has to satisfy certain model requirement criteria. The model checking includes the following basic aspects:

i) *Material Definitions*

Elastic Modulus, Poisson's Ratio and material density are defined in a consistent unit system.

ii) *Element Thickness/Cross-section Properties*

Net plate thickness is defined for plate or membrane elements. Corrosion margins are deducted in calculating the cross-sectional properties of rod/beam elements. The attached plate should be included in the beam moment of inertia calculation with the neutral axis located at the center layer of the attached plate. The attached plate should not be included in the cross-sectional area calculation.

iii) *Element Shape*

Element shapes of the model should be screened for:

- Aspect ratio
- Taper
- Warping and internal angles
- Free edge
- Coincident nodes and elements
- Element overlapping

Extreme shape elements should be remedied unless they are unavoidable.

Generally, the screening tolerance limits are:

- Aspect ratio should be less than 3
- Taper should be less than 10
- Warping should be less than 5 degrees
- Internal angle should be not less than 30 degrees
- No free edge caused by wrong element connectivity
- Coincident (duplicated) nodes should be checked and merged
- Coincident (duplicated) elements should be checked to avoid incorrect property
- An element overlapping two adjacent tanks should be avoided

Duplicated elements may cause incorrect plate thickness/element properties unless modeled on purpose. There are two kinds of duplicated elements – duplication of two identically shaped elements (normal duplication) and duplication of differently shaped elements (abnormal duplication). Normally duplicated elements are easily corrected. Special attention is needed to identify and correct the abnormal duplication.

Overlapping elements cause more problems for loading and evaluation. A typical problem is when an element overlaps two adjacent tanks, which usually happens at the connection between the upper sloping bulkhead and the transverse corrugated bulkhead. This overlapping may cause tank boundary identification problems and affect loading.

13 SafeHull Verification Tools

SafeHull Nastran model checking tool (see Section 2, Figure 9) can help users finding the areas of problem against the above-quoted criteria. This tool can also fix those problems. Application of this tool is strongly recommended before loading to the FE models.

FIGURE 9
SafeHull Nastran Model Check Tool

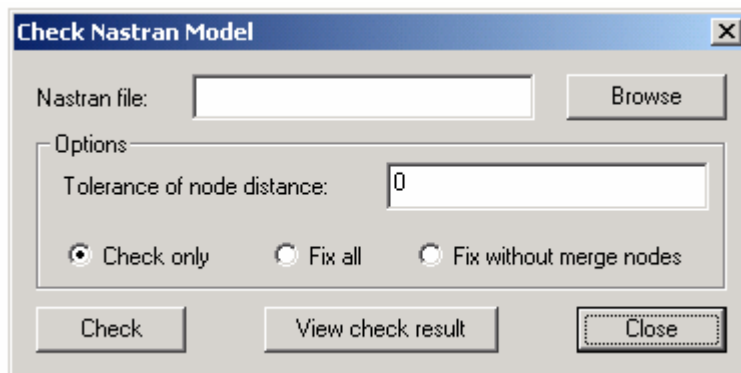

SafeHull also provides model grouping tool, which may help users to verify the meshing quality and properties of each element graphically.

FIGURE 10
SafeHull Groups and Displays the Model by Grouping Parts

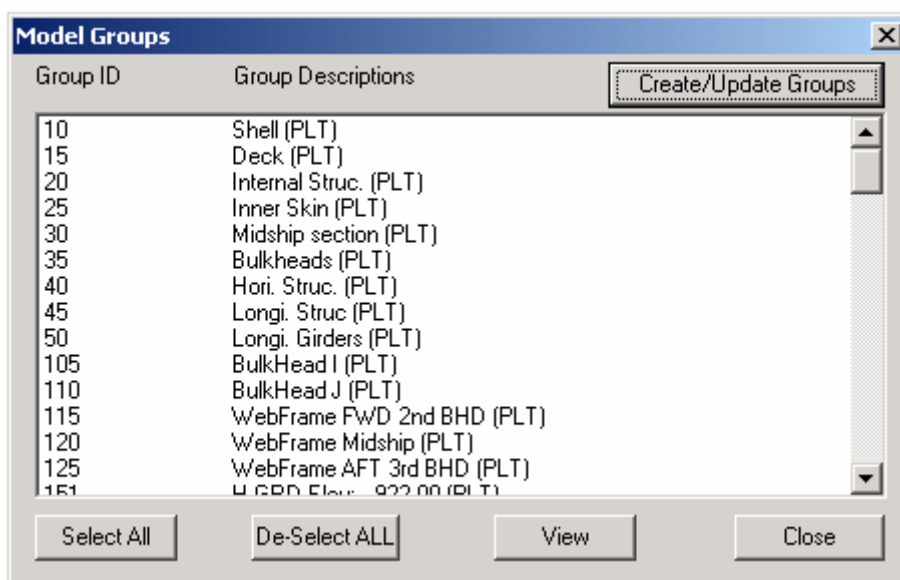



SECTION 3 Loading and Boundary Conditions

1 General

An oceangoing or in-harbor vessel encounters the following loads:

- Wave-induced hydrodynamic pressure acting on the external hull surface
- Hydrostatic pressure of sea water acting on the external hull surface
- Motion-induced dynamic cargo and ballast pressures or forces (for container carriers) acting on the cargo and ballast tank boundary surfaces
- Hydrostatic pressure of cargo and ballast acting on the cargo and ballast tank boundary surface
- Structural weight

Since only three cargo holds are used for FE modeling, desired distribution of hull girder shear forces and bending moments can't be achieved by applying the abovementioned loads alone. In addition, interaction forces acting on the model boundaries must be also considered.

In applying the above loads, the first step is to identify the boundaries of cargo holds and ballast tanks, represented in the FE models. The ABS SafeHull software system adopts the "loading by tank" approach for this purpose.

3 Loading and Loading Patterns

For oceangoing vessels, all loads, previously mentioned, are dependent on the sea conditions, vessel speed, vessel type, cargo carried, cargo arrangement, and so on. Based on the experiences accumulated by lot of DLA analyses applied to many categories of vessels, ABS developed the design loading conditions together with corresponding criteria for the strength assessment of tankers, bulk carriers and container carriers.

It is not the goal of this Guide to explain the loading criteria. Section 3, Table 1 lists the paragraph numbers in the *Steel Vessel Rules* of the formula for the specific load calculations.

TABLE 1
Steel Vessel Rules Specified Loading Criteria (150 m or More in Length)

<i>Vessel Type</i>	<i>Hull Girder Loads</i>	<i>External Pressure</i>	<i>Internal Pressure</i>
Tankers	3-2-1/3.1-3.5; 5-1-3/3.1-5.3	5-1-3/5.5	5-1-3/5.7
Bulk Carriers	3-2-1/3.1-3.5; 5-3-3/3.1-5.3	5-3-3/5.5	5-3-3/5.7
Container Carriers	3-2-1/3.1-3.5; 5-3-3/3.1-5.1	5-3-3/5.3	5-3-3/5.5

The *Steel Vessel Rules* also specifies the loading patterns, considering the wave conditions and all possible cargo or ballast arrangements to create the worst case loading condition. Section 3, Table 2 lists the *Steel Vessel Rules* specified load patterns.

TABLE 2
Steel Vessel Rules Specified Loading Patterns

<i>Vessel Type</i>	<i>Hull Girder Loads</i>
Tankers	5-1-3/Figure 1 & Figure 14
Bulk Carriers	5-3-3/Figure 1
Container Carriers	5-3-3/Figure 3

5 Load Combination Factor and Load Cases

After calculating all of the previously-mentioned loads for the *Steel Vessel Rules*-specified loading pattern, the load components are combined by using the load combination factors (LCFs) to create the different load cases. For all load components, there are corresponding LCFs. In some cases, the load component may be divided into sub-components, such as longitudinal, transverse and vertical components. The LCFs and corresponding load cases can be found in the *Steel Vessel Rules* tables listed in Section 3, Table 3.

TABLE 3
Steel Vessel Rules Specified Loading Combination Factors

<i>Vessel Type</i>	<i>Hull Girder Loads</i>
Tankers	5-1-3/ Table 1 & Table 2
Bulk Carriers	5-3-3/ Table 1
Container Carriers	5-3-3/ Table 1

7 Identify Compartments

SafeHull loads the model for each tank (compartment). SafeHull treats the hull external surface as an external tank.

Tank identification is one of the most important aspects for *Steel Vessel Rules* loading. SafeHull provides two tank identification tools:

- Quick Tank Search tool
- Extensive Tank Search tool

In general, if the users follow the modeling guide described in Section 2, “Global 3D FEA Model”, the quick tank search identifies all tank boundaries in a very efficient manner. When tanks cannot be identified by the quick tank search, the extensive tank search is applied. The extensive tank search identifies any tank boundaries.

SafeHull provides a tank search report (log file) to provide information for the tank search. It also provides a graphic viewing tool to view the searched tank boundary elements. The log file and the viewing tool provide information for modeling problems. View the tank boundary search results using the tools provided in Section 3, Figure 1 to verify that all of the tank boundaries are identified correctly. All tank boundaries must be identified correctly before applying the loads.

FIGURE 1
SafeHull “View Tank Boundaries” and “Search Log File” Tools

Tank ID and Name:	Log File Name:	Number of Elements	Number of Warnings	Number of Errors
1 SHELL01	afamax.01_LOG	9792	0	0
2 W_CG002	afamax.02_LOG	3972	0	0
3 W_CG003	afamax.03_LOG	3972	0	0
4 W_CG004	afamax.04_LOG	3972	0	0
5 W_CG005	afamax.05_LOG	3952	0	0
6 W_CG006	afamax.06_LOG	3952	0	0
7 W_CG007	afamax.07_LOG	3952	0	0
8 JBLST08	afamax.08_LOG	3590	0	0
9 JBLST09	afamax.09_LOG	3590	0	0
10 JBLST10	afamax.10_LOG	3590	0	0
11 JBLST11	afamax.11_LOG	3576	0	0
12 JBLST12	afamax.12_LOG	3576	0	0
13 JBLST13	afamax.13_LOG	3575	0	0

Buttons: Select All, De-Select All, Check Log Files, View Tank, All Tanks View, Close

Merge Log Files

9 Apply Load Components to Compartment Boundaries

Based on the types of load components, the SafeHull system computes the pressures or forces for each tank according to the *Steel Vessel Rules*-specified loading criteria (Subsection 3/3, “Loading and Loading Patterns”), loading pattern (Subsection 3/3) and load combination factors (Subsection 3/5, “Load Combination Factor and Load Cases”) of the Rules-defined load cases (Subsection 3/5). The calculated loads are automatically applied to the tank boundary elements (nodes). The loading by tank approach provides a simplified way to examine different types of load components.

SafeHull provides the visualization tool (see Section 3, Figure 2) to review the tank load for selected load cases for one or all tanks. The user can also review the pressure distribution of different tanks at a specified frame section. Use the tank-load-reviewing tool to verify both the applied pressure and force direction by vector, including the projected component and magnitude.

11 Pressure Superposition and Force Conversion

Once pressure is calculated for each tank, pressure on the common tank boundaries acting on the same element and node are superimposed to obtain the total pressure value. Then, the pressure is converted to nodal force, weighted by the areas of connecting elements.

FIGURE 2
SafeHull “View Tank and Frame Load” Tool

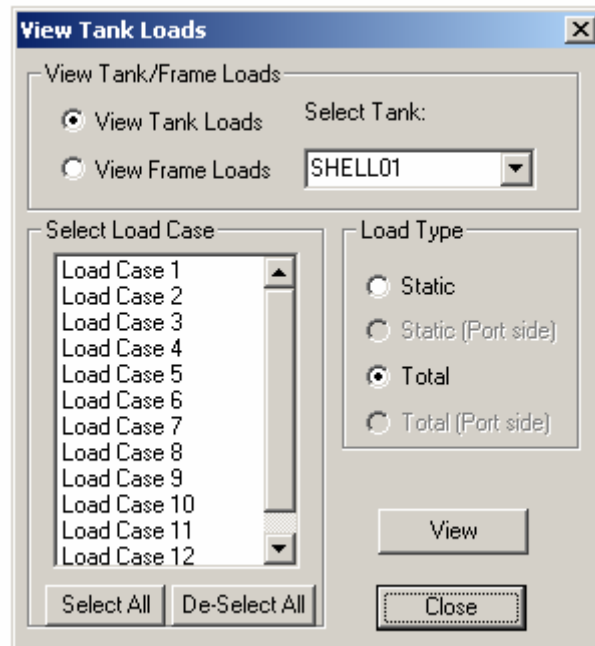

13 Hull Girder Loads and Load Equilibrium

As mentioned in Subsection 3-3, the FE model only contains a portion of the vessel. The local loads acting on the three cargo holds only provide a partial load contribution to the overall hull girder loads. In order to use the three-hold model to predict vessel responses, adjustment must be made for the hull girder load to reach the Rules target values. The SafeHull system automatically adjusts the load by either inertia force or line loads, in addition to adjusting end moments.

When adjustment is completed, all loads acting on the finite element model develop the hull girder target bending moment at the middle section of the middle cargo hold, and hull girder target shear forces at the transverse bulkheads of the middle cargo hold. The SafeHull system provides the plots to verify the hull girder load distribution (see Section 3, Figure 3). These plots include the load, hull girder shear and hull girder bending moment distribution curves before and after the adjustment.

The accuracy of the hull girder bending moment adjustment can be verified by using a simple beam bending stress calculation, checking the deck or bottom plate stress using the following formula:

$$\sigma_x = \frac{My}{I}$$

Note: It is recommended that the deck plate be used in the above formula since the local load has a significant affect on the bottom plate.

where

- M = target vertical bending moment
- y = coordinate of the plate measured from the cross section neutral axis
- I = moment of inertia of the cross section

All three values can be found in SafeHull output files. If the stress, calculated by the above formula, is close to those from the FE results (with several percentages tolerance), the vertical bending moment adjustment can be considered complete.

FIGURE 3
View Curves of Hull Girder Load in the SafeHull System

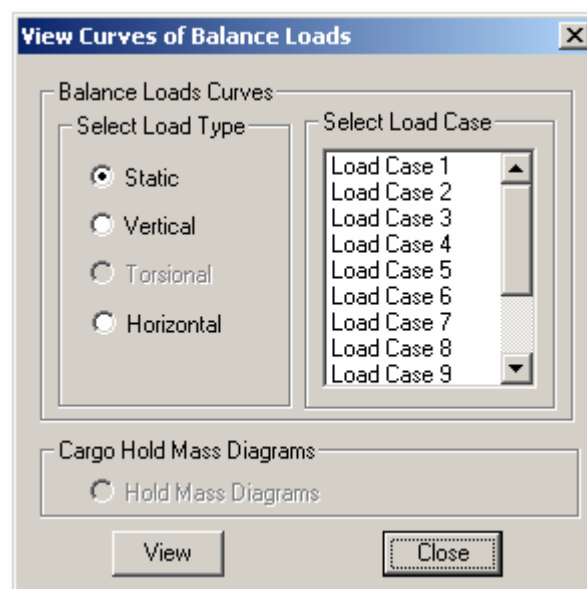

15 Boundary Conditions

In the state of static equilibrium, the free body of the hull girder is subjected to bending and torsional moments, as well as shear forces at two ends. These end actions are expressed as normal and shearing stresses on the hull girder and as boundary nodal forces imposed on the model. Even though the local and boundary loads are in equilibrium, the finite element model still needs some support in order to be statically stable. These supports are arranged in the way thereby minimizing the effects on the hull girder vertical, horizontal and torsional bending moments distribution on the model.

15.1 Supporting Rod and Its Property

Since forces and moments in the hull girder structures are not always completely balanced, it is recommended that special boundary supports be applied using rod elements in both the vertical and horizontal directions. These supports should have one end connected to the model and the other end totally fixed.

The cross sectional area of the supporting rod elements for tankers and bulk carriers is calculated as:

$$A = \left(\frac{1}{1 + \nu} \right) \frac{A_s \ell}{L} = 0.77 \frac{A_s \ell}{L}$$

where

- A = cross-sectional area of the supporting rod element
- ν = Poisson's ratio of the material
- A_s = shearing area of the entire cross sectional area of the member (such as the cross-sectional area of the considered side shell or longitudinal bulkhead)
- L = cargo hold length (i.e., one half span of the beam)
- ℓ = length of the supporting rod element

The resulting cross-sectional area, A , is the total equivalent area for the supporting rod elements connected to the same structural member (e.g., shell or longitudinal bulkhead). The area for the supporting rod is equal to A divided by the number of rods.

15.3 Tankers

The location for the supporting rod elements of three types of tankers is shown in Section 3, Figure 4. In addition to the vertical and horizontal supports, two points on the longitudinal bulkheads intersecting with side stringers and close to the vertical hull girder neutral axis must be directly fixed in the longitudinal direction (x).

FIGURE 4
Spring Supports for Tanker Global Models

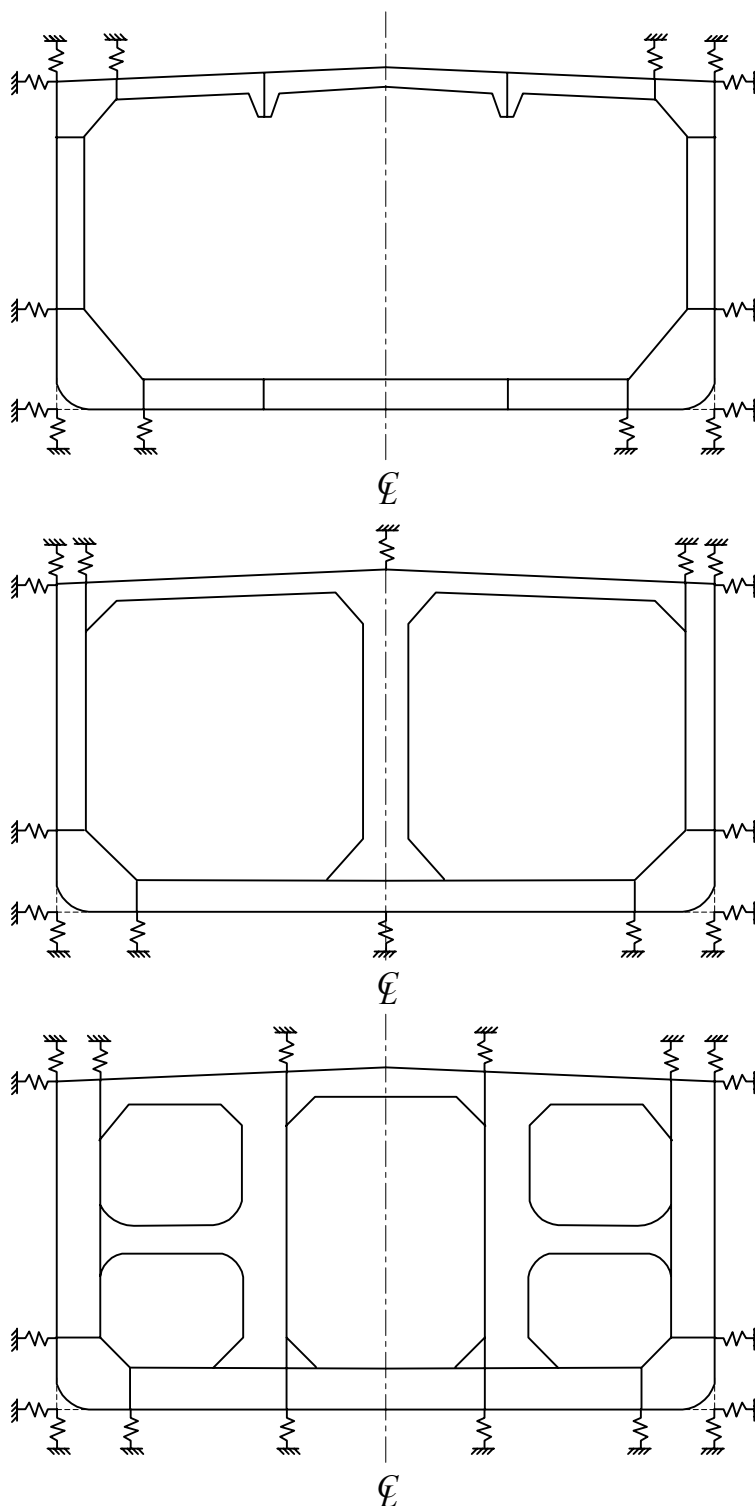

15.5 Bulk Carriers

In the SafeHull System for Bulk Carriers loading, torsional moments are to be accounted for in both oblique and beam sea conditions. Unlike a typical tanker which does not have wide cargo hatch openings in the deck structure, a bulk carrier's cross deck structure experiences large shear and warping stresses due to a significant amount of torsional moment induced in oblique sea conditions. This is mainly due to the location of the shear center of a bulk carrier, which is below the baseline of the hull. The shear center for tankers is located close to the center of gravity. In addition, a bulk carrier's open deck structure has relatively less strength than that of a tanker.

In order to enable an appropriate application of torsion in the finite element analysis of a three-cargo-hold model, a different set of boundary supports than those used for a tanker is required. The supports at the two ends of the finite element model used in tanker structural analysis are changed to supports at only one end. In this scheme, the fore end of the model is supplied with vertical and lateral rod supports. The vertical supports are placed at longitudinal bulkheads and the side shell. Horizontal supports are placed at the deck, inner bottom and bottom shell for both the port and starboard sides (see Section 3, Figure 5).

FIGURE 5
Spring Supports at Fore End of Bulk Carrier Global Models

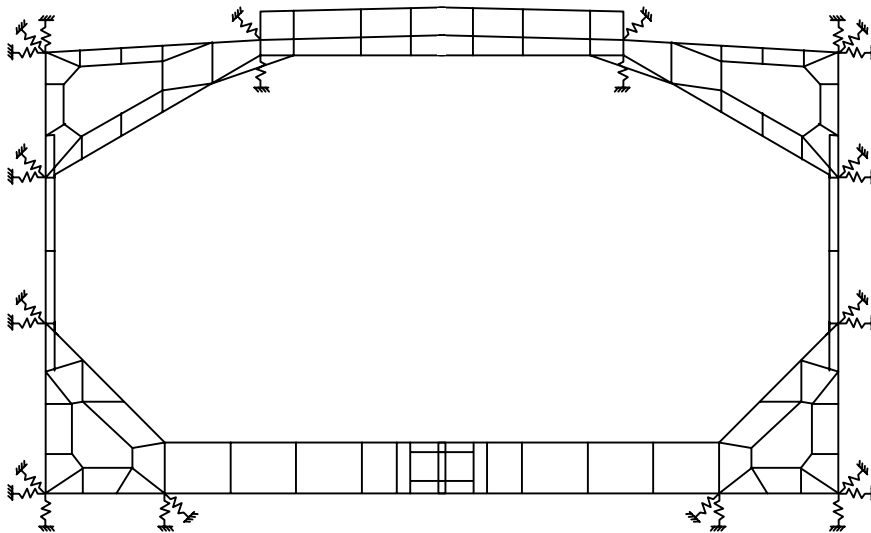

This spring system provides vertical and transverse supports to the finite element model. In order to have a statically stable structure, additional supports in the longitudinal direction have to be provided. The longitudinal spring supports are placed at the same location as the vertical and/or transverse supports. The rod element, which is representative of the stiffness of the longitudinal spring support, can be chosen from one rod element with medium stiffness among those that represent vertical and horizontal spring supports.

In the analysis of the structural response, all nodal points for the spring supports should be totally fixed. That is, all six degrees of freedom for the support nodes should be set equal to zero. At the aft end of the model, no supports are provided. Moments and shear forces are applied at both the aft end and forward end of the model. The boundary vertical and horizontal moments can be expressed in terms of hull girder bending stress and imposed on the model as boundary longitudinal nodal forces. The boundary vertical shear force can be expressed in terms of boundary nodal forces applied to the side shell and boundary lateral shear force expressed in terms of boundary nodal forces imposed on both the deck and the bottom shell. The boundary torsional moment can be expressed in terms of a force-couple and imposed on both deck and bottom shell as boundary nodal forces. Boundary vertical bending moment, boundary vertical shear force, torsional moment, horizontal bending moment and horizontal shear are to be applied at the aft end of the model.

15.7 Containership Models

In the state of static equilibrium, the three-hold free body of the hull girder is subjected to bending and torsional moments and shear forces at two ends. These end actions are expressed in terms of hull girder normal and shearing stresses and imposed on the model as boundary nodal forces. However, even though the local and boundary loads are in equilibrium, the finite element model still needs some supports to be statically stable. For this purpose, spring supports are introduced at the two ends of the model. These supports take any unbalanced local and hull girder loads imposed on the model.

In the SafeHull System for Container Ships, the spring supports of the model are placed at the two transverse bulkheads next to the ends instead of on the two end frames of the three-hold model. This is done to better assure that the boundary loads (mainly torsional loads) imposed on the two ends are “absorbed” more directly by the hull girder structure and less by the spring supports. For the same reason, the spring constants of the supports are further softened to ensure that other than unbalanced loads, only insignificant boundary loads are transmitted to the spring supports.

Section 3, Figures 6 and 7 show the arrangement of the spring supports at the two end transverse bulkheads of the model. At the after end, there is one vertical spring element and one horizontal spring element. Both elements are attached to the node at the intersection of the baseline and centerline. At the forward end, there are one horizontal spring element, two vertical spring elements and two longitudinal elements. The horizontal spring element is attached at the intersection of baseline and centerline. The vertical and longitudinal spring elements are attached to nodes that are in line with inner skin bulkheads. As is done for tankers and bulk carriers, the effects of shear forces on bottom longitudinal girders and horizontal stringers are considered negligible in the global analysis.

The stiffness for the longitudinal spring can be chosen to be the same as that of the vertical spring at the same location. It is expected that the reaction from any unbalanced loads in the longitudinal direction can be ignored. All nodal points for the spring supports should be totally fixed. That is, all six degrees of freedom for the support nodes should be set equal to zero.

FIGURE 6
Spring Supports at Aft End for Container Carrier Global Models

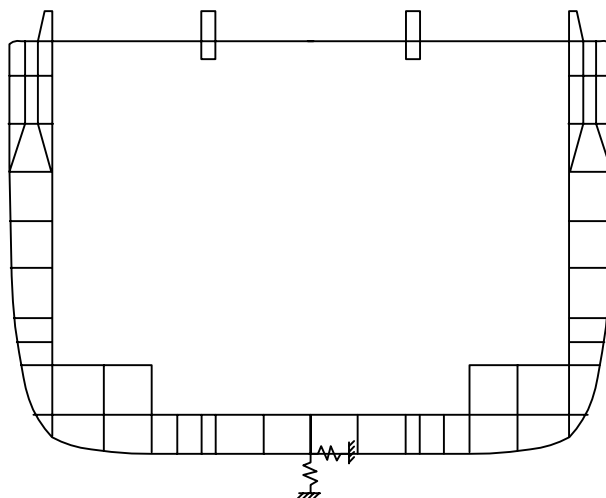
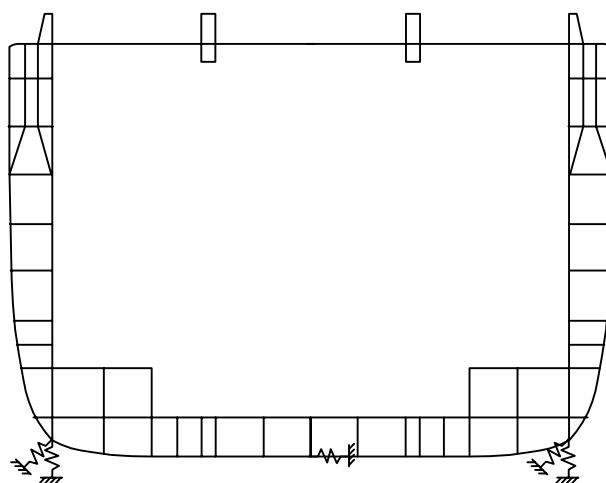

FIGURE 7
Spring Supports at Fore End for Container Carrier Global Models



15.9 Boundary Constraint Beams on the Two End Sections

For the three-hold model, it is important to include the warping constraint from the cut off part of the hull girder. This is simulated by adding out-of-plane bending stiffness to the end sections of the model. This is accomplished in the SafeHull system for container carriers by adding a series of “boundary constraint beams” on the two end sections at all longitudinally continuous structural members. For simplicity (to disregard the orientation of the beams), the same flexural stiffness and shearing areas are assumed for both major and minor axes, even though only the out-of plane bending and shearing stiffness is significant in this situation. All beams are assumed to have identical properties. Based on a calibration study, the following values are suggested for use in the model:

Moments of Inertia:

$$I_{yy} = I_{zz} = I_{zz} \text{ (or } J\text{)}$$

= 1/3 of the vertical moment of inertia of the hull girder amidships

Other properties:

$$A_x = A_y = A_z$$

= 1/10 of the bottom plating cross-sectional area amidships

Use the beam of the vessel times the thickness of the major portion of the bottom plating for the needed bottom plating area. A more detailed calculation using the varying thickness at the keel and bilge areas is unnecessary.

The above values were derived based on a parametric study performed on four containerships, comparing the behavior of the whole-ship models with their respective three-hold models under torsional loads. The boundary constraint beams obtained using these estimated properties produced reasonably accurate warping constraint within the middle cargo holds of the three-hold models as compared to the behavior of the whole-ship models for all four ships.

This Page Intentionally Left Blank



SECTION 4 Evaluation

1 General

There are three basic types of strength criteria used in the “Total Strength Assessment”, as specified in the *Steel Vessel Rules*. They are yielding, buckling and fatigue. Section 4, Table 1 lists the section number of the *Steel Vessel Rules* for yielding, buckling and fatigue evaluation criteria.

TABLE 1
Steel Vessel Rules-specified Loading Criteria
(150 meters or more in length)

<i>Vessel Type</i>	<i>Yielding</i>	<i>Buckling</i>	<i>Fatigue</i>
Tankers	5-1-5/3	5-1-5/5	5-1-5/7; 5-1-A1
Bulk Carriers	5-3-5/3	5-3-5/5	5-3-A1
Container Carriers	5-5-5/3.1-3.5	5-5-5/5.1-5.13	5-5-A1

The evaluations associated with the Global FEA are detailed in the following sections. The evaluations associated with additional local fine mesh analyses are included in *The Finite Element Guide for Hull Structures, Local 3D Approach*.

3 Checking Global Model Response

The global FE model response check serves two main purposes:

- i) To verify overall accuracy of the global model
- ii) To confirm the proper handling of local and hull-girder loads

First, the overall deformations of global models should be checked visually. The SafeHull system provides the visualization tool to review the FEA results in terms of deformations and stresses (see Section 4, Figure 1).

If global models consist of membrane and rod elements, abnormal deformation of structural members may result. This is usually due to loading on unsupported structural nodes. If this is the case, appropriate nodal point constraints (such as slave-master constraints) or load shifting must be applied.

FIGURE 1
View FEA Solution in SafeHull System

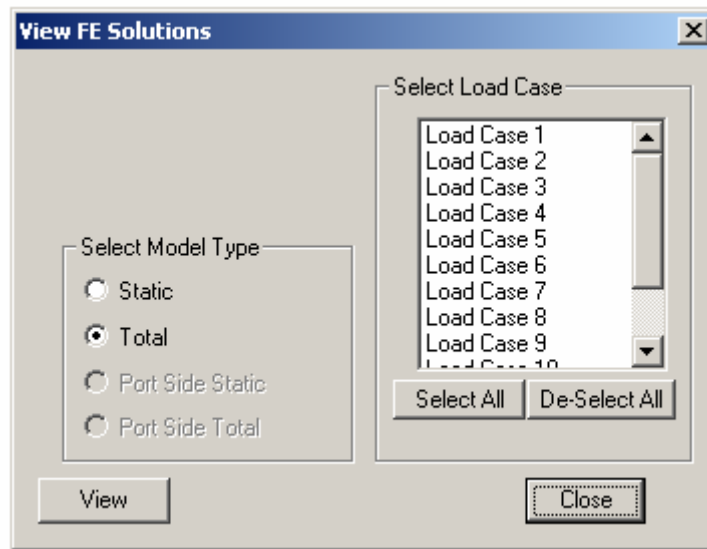
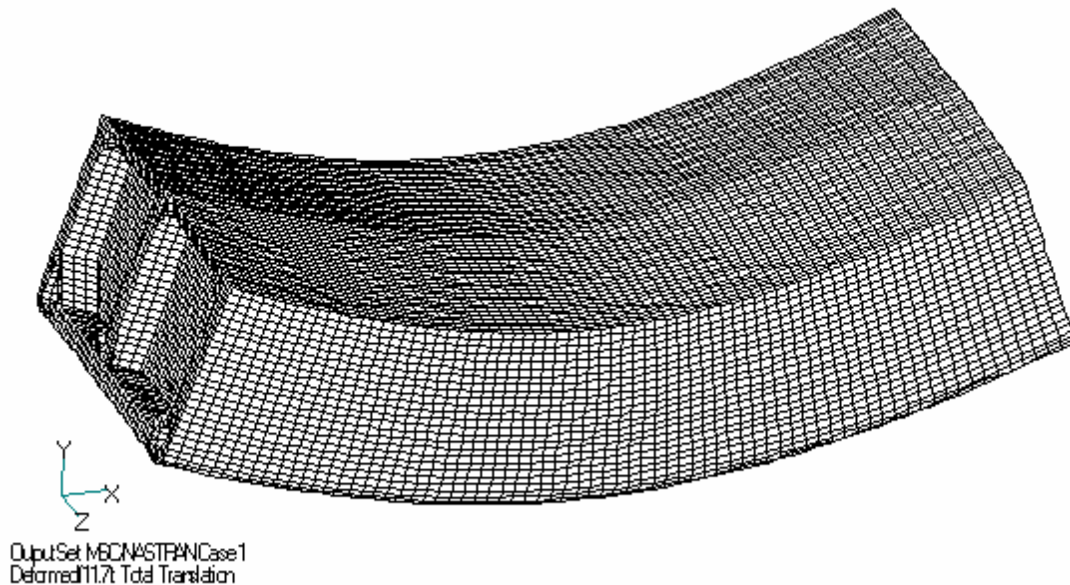

FIGURE 2
Overall Deformation of Three Cargo Model for Load Case 1

VI



The next step in checking the FE results is an examination of the hull girder bending stress and deflection patterns. It has been shown that the primary hull girder bending stress and deflection patterns obtained by the finite element analysis are in agreement with those determined by the classical beam theory, even with an open deck configuration of the hull girder. In order for verification of modeling and loading, a comparison with the results obtained by the beam theory is recommended.

This comparison should be made at the middle of mid-hold in the areas where the effects of local loads are not significant. Hull girder stress, reliable for this purpose, is obtainable from the plate elements of upper deck not connected with other deep supporting members, such as side shell, transverse webs, longitudinal bulkheads, etc. Examination of unusual deformation of the structures always helps users in detecting possible errors in modeling and/or loading.

5 Plate Panels for Evaluation

Yielding and buckling strength of plate panels between stiffeners are evaluated by SafeHull requirements. Panels of watertight structures and non-tight structures, such as main supporting structures, are dealt with differently. Necessary input data files are easily generated by the system.

To define a plate panel of watertight structural members, users need to specify the length, width and panel direction along with other information. Plate and stiffener elements are also included in the panel definition for retrieving stresses from the FE results.

Non-watertight structural members are generally evaluated using finer mesh models. Panels of non-watertight members are to be defined by nodes at their four corners, and averaged stresses are re-calculated for buckling strength evaluation. Yielding strength of non-watertight members is evaluated by their element stresses.

SafeHull provides procedures to sort yielding and buckling evaluation results in a tabular form. This table displays yielding and buckling factors, group by group, of structural members.

7 Yielding Strength

The combined effects of all of the calculated stress components are not to exceed the limits specified in the *Steel Vessel Rules* for the plates, which are subject to both in-plane and out-of-panel loads. This is applicable to the watertight boundaries of the hull structures and distinguished as yielding criteria for watertight members (primary structural members). Other type of yielding criteria is specified for non-watertight members (main supporting structural members).

7.1 Yielding Criteria for Watertight Members

Stress intensity (f_i) is not to exceed the yield strength of the material multiplied by the applicable strength reduction factor (S_m). This limit has been established theoretically and calibrated to the database of vessels, which were available when the criteria were developed. Accordingly, applying this limit to new designs is equivalent to comparing new designs with existing ones using the “same tool”. The “same tool” in this instance is the FEA method in conjunction with the same loading conditions and FEA modeling.

With the introduction of the finer-mesh Global 3D models, instead of the old coarse mesh models, higher stresses have been found resulting from the same loading conditions. Mesh size in global FEA models, when the criteria was developed, were more than 2~3 stiffener-spaces in the transverse direction and one transverse web frame spacing in the longitudinal direction (coarse mesh). Within each coarse mesh element, there can be about 6~12 finer mesh elements of current models.

In order for our old criteria to be applied to the current models, corresponding membrane stresses can be estimated by taking the average of the stresses of the finer mesh elements inside of the one coarse mesh element. This adjustment has been tried successfully and is applied in the Global 3D Analysis. This change of evaluation method is most explicit when there are abrupt changes of stress distribution or heavy structural discontinuity.

Stress intensity (f_i), as defined in the Rules, consists of several components that can be categorized in two groups:

- i) Membrane stresses derived from FEA
- ii) Out-of-plane stresses (bending stresses of small stiffeners and tertiary stresses). These are estimated by formulas and added to the membrane stresses derived from FEA.

Accordingly, changing the evaluation method is to be done by adjusting the membrane stresses from the FEA.

7.3 Yielding Criteria for Non-watertight Members

Only membrane stresses of FE results are checked against the criteria ($f_m * S_m * f_y$), f_m varying depending on the mesh sizes, where to check and materials (1.00 ~ 1.75). Since the criteria are so dependent on structural details, individual application will be explained in the separate document “Guidance Notes on Finite Element Analysis of Hull Structures – Local 3D Model Analysis”.

Recent study necessitated minor changes be applied to the requirements for some structural members, especially for bulk carriers at the ends of double bottom floors and girders, which intersect with longitudinal and transverse stools on tank top, respectively. New requirements have been already effected in the system.

9 Buckling Strength

Similar to the yielding evaluation, there are two types of buckling strength criteria:

- Buckling criteria for watertight members
- Buckling criteria for non-watertight members

9.1 Buckling Criteria for Watertight Members

The concept, previously mentioned for the yielding evaluation, of taking the averaged stresses of several fine mesh elements inside of one coarse mesh element is also applied to the buckling evaluation of watertight members.

9.3 Buckling Criteria for Non-Watertight Members

SafeHull utility programs for the buckling strength evaluation of non-watertight members can be applied to the panels with rectangular shape. No openings are allowed in the panels. Plate thickness is assumed to be uniform inside one panel. Each panel is to be defined by four (4) corner nodal points, and the panel’s average stress components are recalculated from their displacements. For non-rectangular panels, the approximation approach based on the same concept for the rectangular is applied.

Each panel usually consists of several elements. Recalculated stress components are considered to be close to the averaged stress components of the elements. However, this is not true when one or more elements are heavily affected by a stress concentration. One such typical location is found at the outboard ends of double bottom floors. Stress concentration is highly localized and its effects must be eliminated when buckling strength is evaluated.

11 Fatigue Strength

In order to perform a practical fatigue strength assessment, there are three features to be developed and calibrated:

- Modeling
- Loading
- Checking against the acceptance criteria

The *Steel Vessel Rules* are very specific about loading. However, there needs to be compatibility between the structural modeling and the acceptance criteria.

The fatigue assessment is usually performed for locations of structural discontinuity where high stress concentration is found by the FEA. The magnitude of this stress concentration partially depends on mesh size at the location of structural discontinuity. It is not unusual to obtain stresses far exceeding the tensile strength of the material. However, this high stress exists only mathematically and does not necessarily lead to failure. In order to eliminate the effects due to this virtual stress from the evaluation, the “Hot Spot Stress” concept is included in the Rules.

The “Hot Spot Stress” is used for checking against two different criteria:

- Permissible Stress Range
- Permissible Total Stress

Permissible Stress Range is tabulated in the Rules depending on the locations and structural details. Permissible Total Stress is introduced to restrict the level of “mean stress” below reasonable limits. Most structural damages appear as a result of the omission of the control of the Permissible Total Stress. Permissible Total Stress is tentatively specified as $(1.75 \cdot 1.00)$ and $(1.50 \cdot S_m)$ times yield strength of mild steel and high tensile steel, respectively. The resultant Permissible Stress obtained is close to the tensile strength of the material.

SafeHull includes a few model templates of typical structures such as access holes, bracket toes and longitudinal stiffener connections. Detail models for fatigue analysis purposes can be created with them. Result sorting and display features are also provided for fatigue analysis procedures.

This Page Intentionally Left Blank

SECTION 5 Critical Areas

1 Tanker

The issues that may dictate the degree of analysis include the following:

- Known problem areas of similar structural arrangements or details
- Relatively high stress levels found in the global FE model
- Areas or details not adequately represented within the global model

Areas that are sometimes subjected to finer mesh analysis include the following:

- Access openings in horizontal stringers
- Bracket toes of main supporting members
- Hopper corner details

1.1 Transverse Web

Double-hull tankers can generally be divided into three distinct configurations, types A, B and C. They increase in size with two, three and four longitudinal bulkheads, respectively.

FIGURE 1
Critical Areas – Tankers

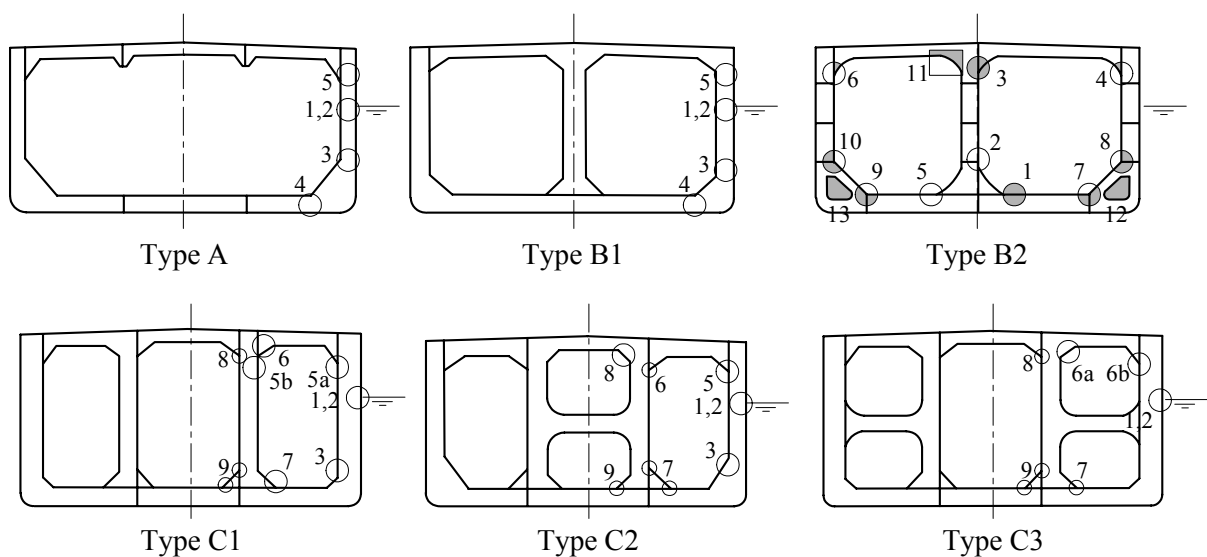

Type A has a simple double-hull form and is typical of small tankers. Type B tankers are usually Aframax and SuezMax with a centerline bulkhead. Type C tankers are common for VLCC and have two additional longitudinal bulkheads with one or two struts in either the center or wing tanks.

Some specific areas, as marked, have been found to be subjected to high stress (against yielding and buckling failures) under various loading conditions, depending on the midship configurations. These high stress areas, except those in Locations One and Two near the full load or ballast water line, are due primarily to high static loads. However, even in the cases with high static loads, significant portions of the stresses are motion-induced and thus may also be susceptible to fatigue damage.

The aforementioned critical locations, which require more detailed modeling and evaluation by the “Local 3D Approach”, are summarized below:

Locations 1 and 2:

Location One is at the connections of the side longitudinal stiffeners near the water line to the transverse web frames. Location Two is at similar connections at the transverse bulkheads. These connections are susceptible to fatigue damage primarily due to cyclic external pressure acting on the ship’s shell by waves and partly to internal pressure fluctuation induced by ship motions. Similar problems occur at the same locations on the longitudinal bulkheads. This is true for all type A, B and C vessels.

Location 3:

Location Three is at the lower part of the side transverse (or the double-side) for type A and type B vessels, as well as type C vessels without struts in the wing tanks. Under large angles of roll, these areas are subjected to high magnitude shearing stresses resulting from significantly higher internal loads induced by the ship’s roll motions. Additional bending by the side transverse under the same loading further raises the stress level a significant amount on the inboard side of the side transverse near the bottom.

Location 4:

Location Four is located at a fixed-end beam subjected to a uniformly distributed load. These “fixed ends” of the double bottom floors connecting to the longitudinal bulkheads usually experience a high magnitude of shearing stress. This is true for both type A and type B vessels, but is more severe for type A vessels. Furthermore, double bottom bending also causes significant additional stress in the floors near the connection of the inner bottom to the longitudinal bulkhead.

Location 5:

Location Five is similar to Location Three, but refers to the upper parts of the vertical webs. These locations at the side and longitudinal bulkhead also often experience high shearing stress. This is because the upper portion of the transverse web is usually designed with lighter scantlings, and under large angles of roll considerable pressure is added to the transverse web resulting in high shear at both ends. Additional bending of the vertical webs and deck transverse webs, also raises the stress level significantly in the area connecting to the deck transverse webs. This is true for type A and type B vessels, as well as for type C vessels without struts in the tanks.

Locations 6 to 9:

Locations Six through Nine are in various bracket connections. In these bracket connections, high stresses are due primarily to the bending of the connecting members, and in some cases, due to shear.

1.3 Horizontal Stringer Sections

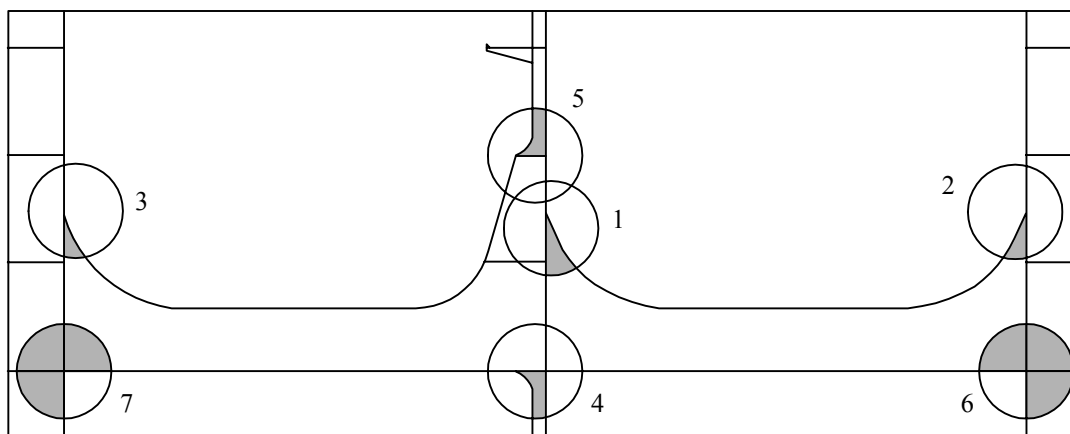

1.5 Longitudinal Girder Sections

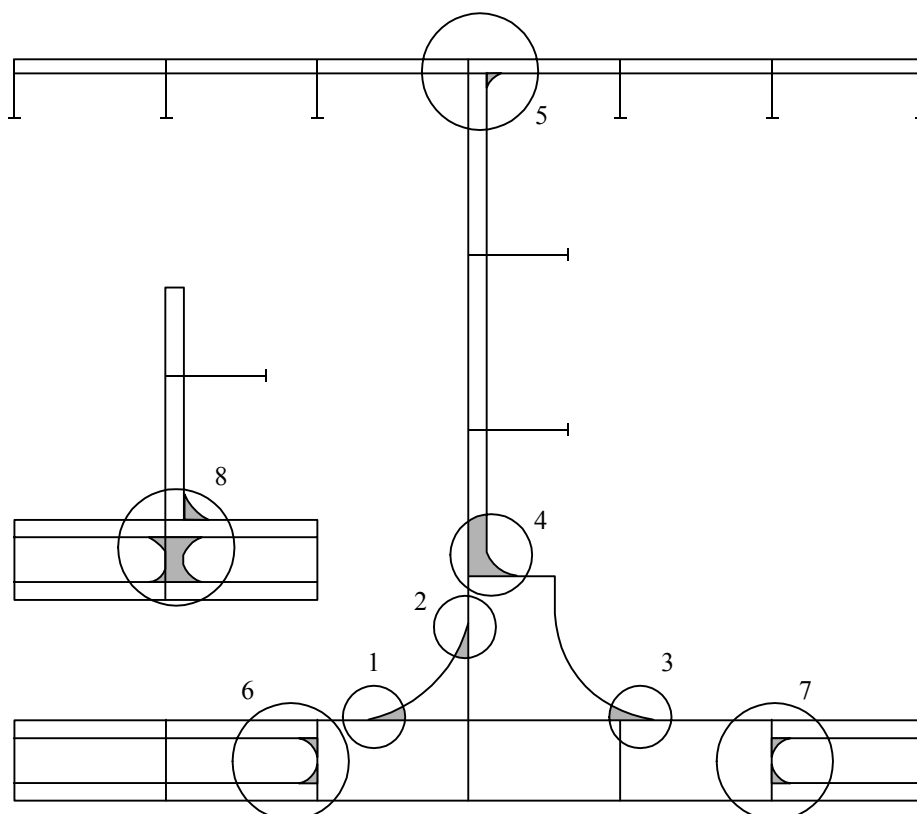

3 Bulk Carrier

Section 5, Figures 2a through 2e show the critical areas for the typical configurations of bulk carriers. The critical areas for an ore/bulk/oil carrier and an oil/ore carrier are similar.

The analyses of the transverse and longitudinal structures primarily consider the overall strength of the internal supporting structures. Therefore, attention is paid to obtaining the local stresses in these structures and the assessment of the yielding and buckling strength.

Section 5, Figure 2a shows the typical failure locations for a general bulk carrier. There are two types of hold frame brackets for Location One, lapped and inserted. The lapped bracket can fail where the bracket is lapped to the hold frame. The distress is likely to occur as fractures in the toe for the insert bracket.

Location 2:

Location Two depicts buckling failures to the upper wing tank transverses. This is more likely to occur where the collar plates are not fitted to the longitudinal stiffeners and skirt plates are not fitted to the corrugation.

Location 3:

Location Three depicts fracturing within the floor web of the lower wing tank. Excessive shear usually causes these failures.

Location 4:

Location Four depicts buckling of the corrugated bulkhead, primarily due to excessive wastage.

Location 5:

Location Five depicts fracturing of the corrugation connection at the upper wing tank, primarily due to excessive stress in the corrugation plate.

Location 6:

Location Six depicts buckling of the coaming plate brackets for the hatch end frame in the upper wing tank. One cause for this failure is due to torsional loading. High shear stress in this area for the 2-D local analysis alerts the user to this possible failure mode.

Location 7:

Location Seven is a typical hatch corner failure, due to excessive stress in the contour bracket. Although the failure is typically associated with a fatigue-induced failure, a stress evaluation of the adjacent deck plating will indicate the severity of the problem. The hatch corner contour is typically an elliptical contour, regardless if it is an insert plate. The stress concentration factor for contour edge stress compared to that of the nominal stress in the adjacent deck plating is often 1.5 and higher.

The situations mentioned previously are a general overview of the most common failures that occur in bulk carriers. Other failure modes listed below are better assessed by alternative means.

- i)* Fracturing or buckling due to excessive wastage
- ii)* Fatigue damage
- iii)* Fractures of inner bottom plating connectivity to lower wing tank plating and stool plating
- iv)* Fractures of corrugation connectivity to stool shelf plating
- v)* Grooving in the welds
- vi)* Fractures of the coaming brackets connectivity to the main deck, both transverse and longitudinally
- vii)* Contact damage due to operational procedures of loading and unloading with subsequent fracturing and buckling.

FIGURE 2
Critical Areas for Typical General Bulk Carriers

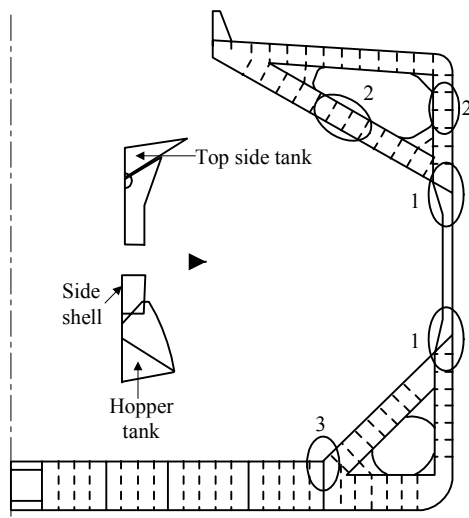

(a) Typical Midship Section

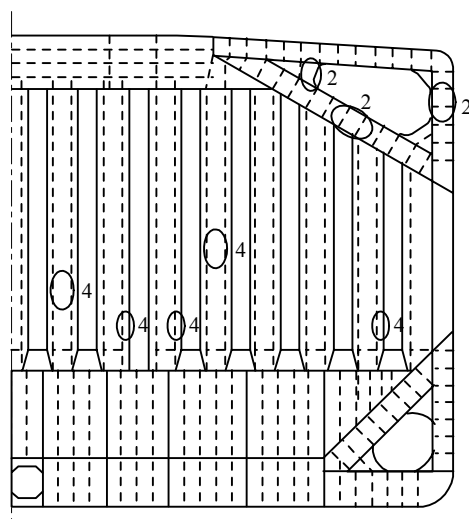

(b) Typical Transverse Bulkhead Section (with stool)

FIGURE 2 (continued)
Critical Areas for Typical General Bulk Carriers

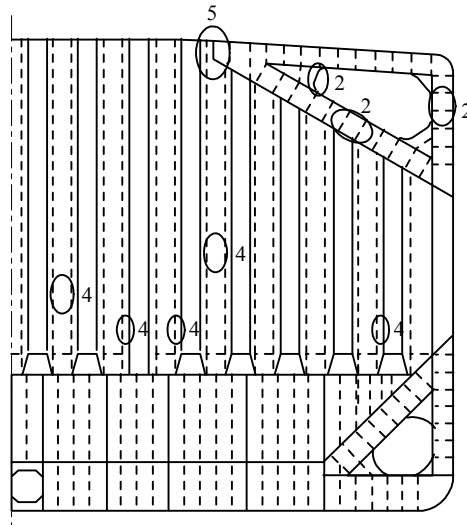

(c) Typical Transverse Bulkhead Section (without upper stool)

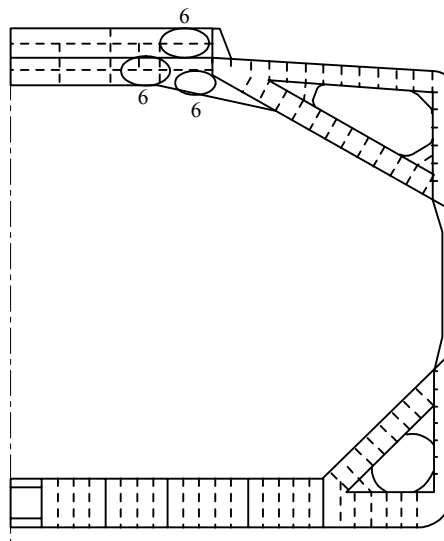

(d) Typical Hatch End Coaming Frame

FIGURE 2 (continued)
Critical Areas for Typical General Bulk Carriers

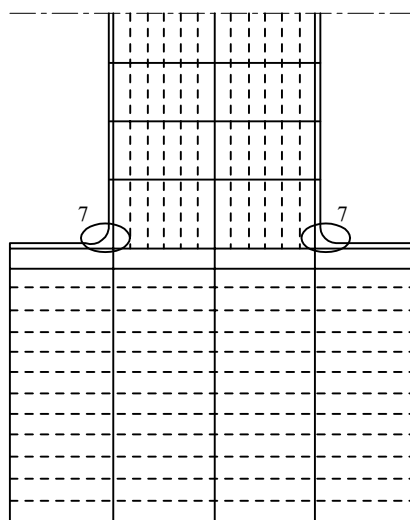

(e) Main Deck

5 Containership

Section 5, Figures 3 and 4 show some critical areas of the typical containership hull structures. These areas are found to be subject to high stress under various loading conditions. Attention is paid to the determination of local stresses in the structures for the purpose of assessing the adequacy of the structures against the failure modes of yielding and buckling. The critical areas marked on Section 5, Figures 3 and 4 are outlined below:

- Intersection of the inner bottom to the inboard longitudinal bulkhead (Location Four). High stress is expected in the floor web at the connection of the inner bottom to the inboard longitudinal bulkhead, due to high shear and double bottom deformation.
- Intersection of the longitudinal bulkhead to the first stringer (Location Five). High stress is also possible at the lower end of the longitudinal bulkhead and in the side web connecting to the first stringer above the inner bottom, mainly due to structural discontinuity at the connection.
- Corners of the hatch coaming top (Location Six). The corners of the hatch side and hatch end coaming top plates are likely to have high stress concentration at midship and forward of the deckhouse, especially due to hull girder torsional loads.
- Main deck hatch corners (Location Seven). Main deck hatch corners are the most critical areas of the containership hull structure, particularly the ones forward of the deckhouse. Excessive stress is expected in their contour brackets due to additional stress caused by warping constraint under torsional loads. Although hatch corner failures are usually associated with fatigue damage, a stress evaluation of the hatch corner or adjacent deck plating can indicate the severity of the problem.
- Mid-hold bulkheads (mid-hold structures, Location Eight). The mid-hold structure which supports cell guides is a load-carrying structure and an integral part of the ship hull. The structure should always be included in the 3-D global model. High stress is possible in some designs and should be closely examined due to cargo hold container loads and interaction with the hull girder structure under various hull girder loads.

- Connection of the longitudinal hatch girder to the hatch end coaming (Location Nine). The hatch side girder is continuous over all cargo holds and should be properly modeled and included in the 3-D global model (with consideration to its typically soft ending). High stress is generally expected at the intersections of the hatch-side girder to the hatch end coaming, which is a result of the hull girder distortion under torsional loads.

FIGURE 3
Critical Areas for Typical Containerships, Transverse Sections

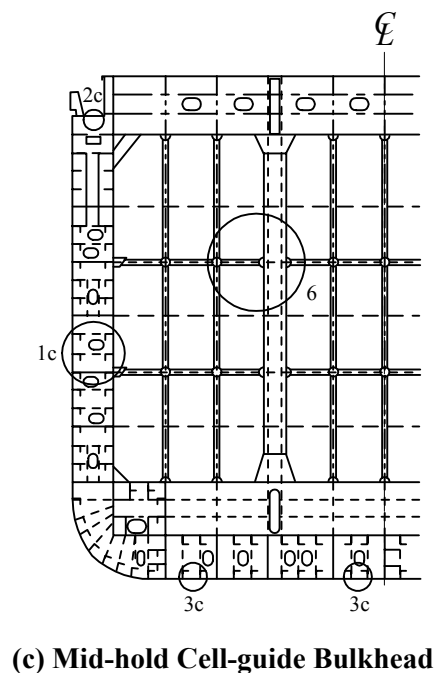
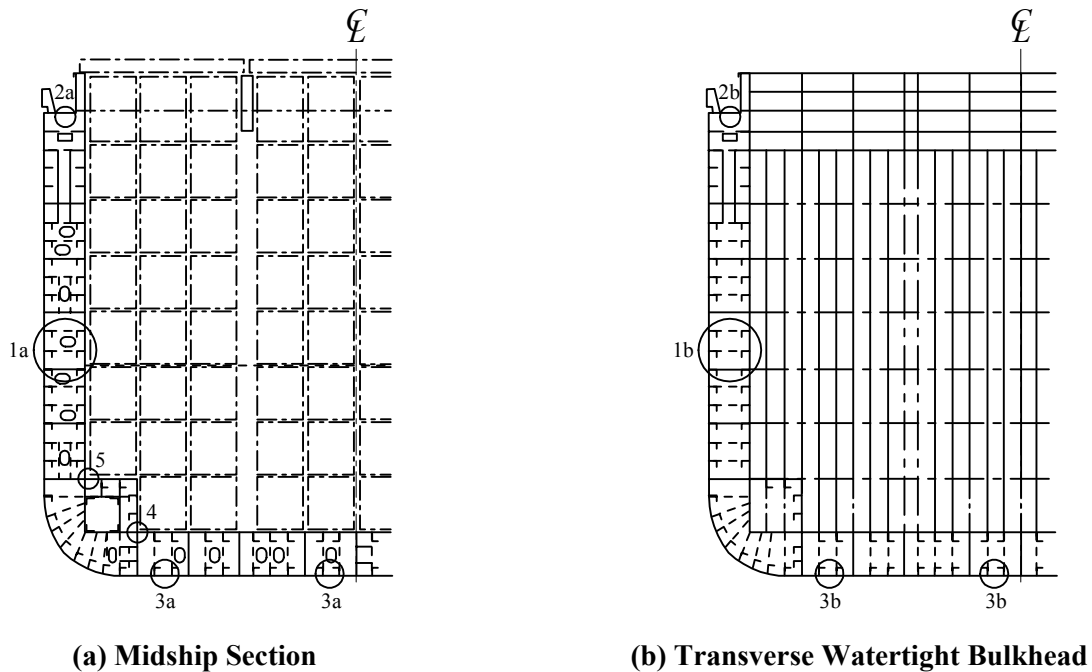
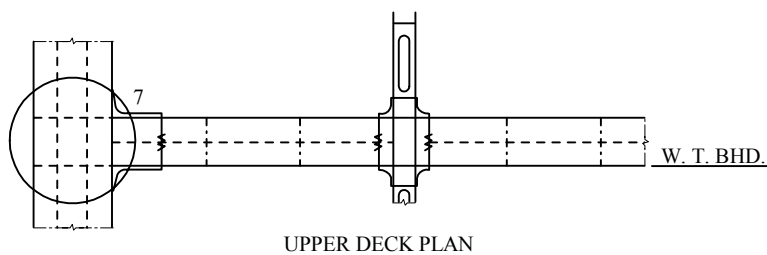
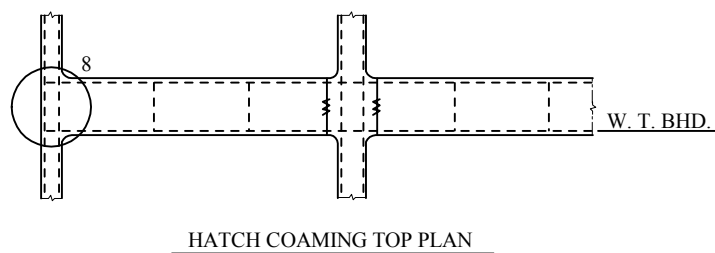
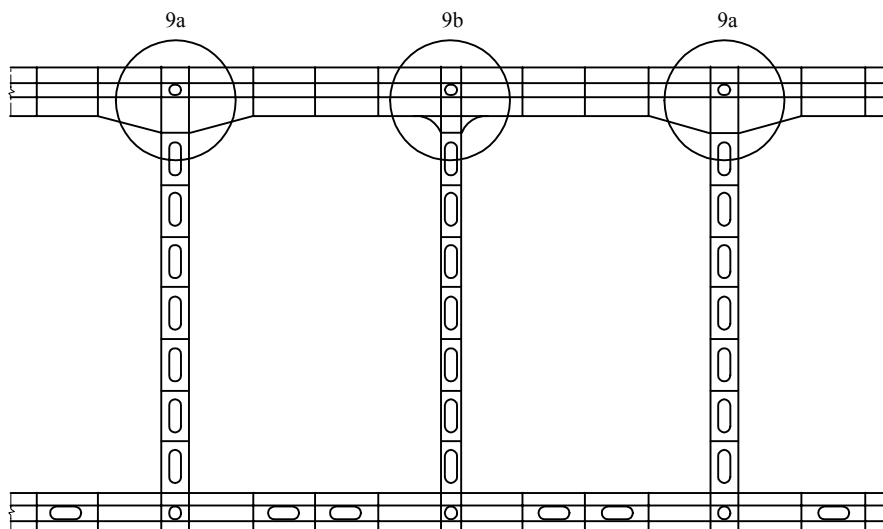

FIGURE 4
Critical Areas for Typical Containerships, Deck & Longitudinal Section



(a) Hatch Corner Connection



(b) Hatch-side Longitudinal Girder

This Page Intentionally Left Blank



SECTION 6 Frequently Asked Questions

Element types for 3D fine mesh global model

(Q) We can use four element types (membrane, bending plate, rod, and beam) to make a 3D fine mesh global model. What element type is to be used for the one step approach?

(A) The one step model may be composed of membrane plates and rod elements. The associated singularity problem is dealt with by “shifting load” and/or “master-slave constraints”. Bending plate and/or beam elements may be used at the user’s discretion if the increased solution time can be tolerated.

Element size for 3D fine mesh global model

(Q) The element sizes for the one-step approach can generally be determined by the spacing of the longitudinal stiffener. In this case, the mesh size isn’t fine enough to model all panel breakers and stiffeners to evaluate buckling at some locations of the transverse web section and horizontal stringer. How should we evaluate buckling in this area?

(A) Mesh size and shape is usually fine enough for checking double bottom floors/girders and side transverse webs and stringers, as well as parallel portions of transverse webs and horizontal girders. However, we note difficulty in defining the panels against buckling evaluation in way of large brackets, since they are comprised of non-rectangular elements.

We have modified the programs in the latest version so that even non-rectangular panels can be analyzed by introducing some parameters.

Small access opening for 3D fine mesh global model

(Q) Openings in main supporting structures should be considered carefully. If small access openings are ignored in the 3D fine mesh global model, how should we consider their effects in the yielding and buckling evaluation?

(A) SafeHull criteria for 2D yielding and buckling are applicable only to intact plates. We must apply different approach/criteria to the panels with openings such as access holes, cutouts for longitudinal stiffeners, etc.

Boundary condition for 3D fine mesh global model

(Q) If simple support of 3 points is applied as the boundary condition for the 3D fine mesh global model instead of current spring supports, high stress concentrations appear at the boundary location.

(A) Supporting models at three points is a new introduction to one-step models. These supports are provided for protection against free movement of the models. If local and boundary loads are not in equilibrium, high stress concentration may result at these points. It is understood that some analysts dislike seeing high virtual stresses, even at the extreme ends of the model. The current programs will be modified for this purpose.

Failure Criteria (Yielding & Buckling) for Fine Mesh Models

(Q) Special consideration should be paid to 3D and 2D yielding and buckling criteria according to the reduced mesh size in the global three-hold-length models. Specifically all elements should be evaluated for yielding and all plate panels and structural members should be assessed for adequate buckling capability.

(A) We are developing utility programs in order to check all elements at one time, which significantly reduces the evaluation time.

3D Buckling Criteria

(Q) 3D buckling evaluation should be checked with the grouping of elements instead of the individual element. How many elements can be used to compose one group?

(A) Note that the requirement tends to be more severe with a finer-mesh global model, so the criteria may be adjusted for the reduced mesh sizes. Since the criteria is calibrated to the FEA results using coarse mesh models, the grouping of several elements into one panel is allowed, provided the resulting panel size does not exceed the original coarse mesh size. That is, panel length being equal to transverse web spacing, while panel width should not exceed three (3) stiffener spacings.

3D Yielding Criteria

(Q) 3D yielding evaluation can be checked with the grouping of elements instead of the individual element. The results of grouping are not much different with individual elements in longitudinal members. However, the results between the grouping of elements and an individual element are sometimes very different in a transverse bulkhead. Can we use the grouping of elements for 3D yielding evaluation at the transverse bulkhead?

(A) Yes, the grouping scheme mentioned for 3D buckling should be used.

2D Yielding Criteria

(Q) In a tanker, the stresses in a typical web section and horizontal stringer from the one-step analysis usually are less than those for a 2D fine mesh analysis at the critical areas. The opposite results are seen for a bulk carrier. Can a different criterion (1.15 x yield strength) be applied for a bulk carrier at the critical area?

(A) The conventional 2D zooming approach has been acceptable as seen from the stresses in the faceplates of deep supporting structures. Significant differences between the results of the two-step and one-step approaches are not expected. Larger differences have only been observed in the double bottom and double-sided structures.

2D Buckling Criteria

(Q) We have neither criteria nor tools for the buckling assessment of non-rectangular panels and panels with openings. How should we evaluate buckling of these panels?

(A) An eigen-value approach may be applied in order for buckling strength evaluation of the panels with the following features:

Non-rectangular form

Non-uniform panel thickness

Openings

High stress concentration

Mesh size for local 3D zooming analysis

- (Q) Can different allowable stresses be applied to yielding criteria according to mesh size?
- (A) Yes. Please refer to the separate document of “Local 3D Approach”.

Critical Area for local 3D zooming analysis

- (Q) If small access openings are ignored in the 3D fine mesh global model, should this area be checked in the local 3D zooming analysis?
- (A) Openings are not to be included in the global one step models. Effects due to any openings in the primary supporting structures should be evaluated by the “Local 3D Approach”.

Critical Area for fatigue zooming analysis

- (Q) The fatigue analysis using local 3D zooming analysis is carried out at the critical area. How many locations are to be checked?
- (A) Most of the structural details, which require fine-meshed zooming analysis, will be explained in the *ABS Guidance Notes on Finite Element Analysis for Hull Structures – Local 3D Approach*.

This Page Intentionally Left Blank



SECTION 7 **References**

1. The *ABS Rules for Building and Classing Steel Vessels*, Part 5, Chapter 1 (Tankers), Chapter 3 (Bulk Carriers), Chapter 5 (Containerships). The latest edition.
2. *Guidance Note on Finite Element Analysis of Hull Structures – Local 3D Model Analysis*, latest edition.

This Page Intentionally Left Blank